

# Wiringkit

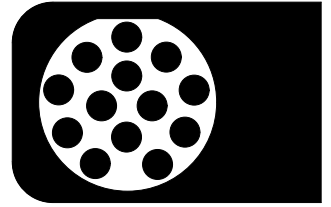

- D Einbauanleitung
- GB Installation instructions
- F Consignes de montage
- NL Montagehandleiding
- DK Montagevejledning
- N Monteringsinstruksjon
- S Installationsanvisning
- FIN Asennusohje
- I Istruzioni per il montaggio
- E Instrucciones de montaje
- P Instruções de montagem
- GR Οδηγίες εγκατάστασης
- CZ Návod k montáži
- SLO Navodilo za vgradnjo
- SK Montážny návod
- PL Instrukcja montażu
- TR Montaj talimatı
- H Beépítési útmutató
- HR Upute o ugradnji
- BUL Инструкция за монтаж
- RO Instrucțiuni de montaj
- RU Инструкция по монтажу и установке
- LT Montavimo informacija
- LV Iemontēšanas pamācība
- EST Paigaldusjuhend

## 701504

VW

- **Passat B8 Variant / Alltrack** 11/14 >>
- **Passat B8 Limousine** 11/14 >>
- **Arteon** 06/17 >>
- **Arteon Shooting Brake** 09/20 >>

LHD + RHD

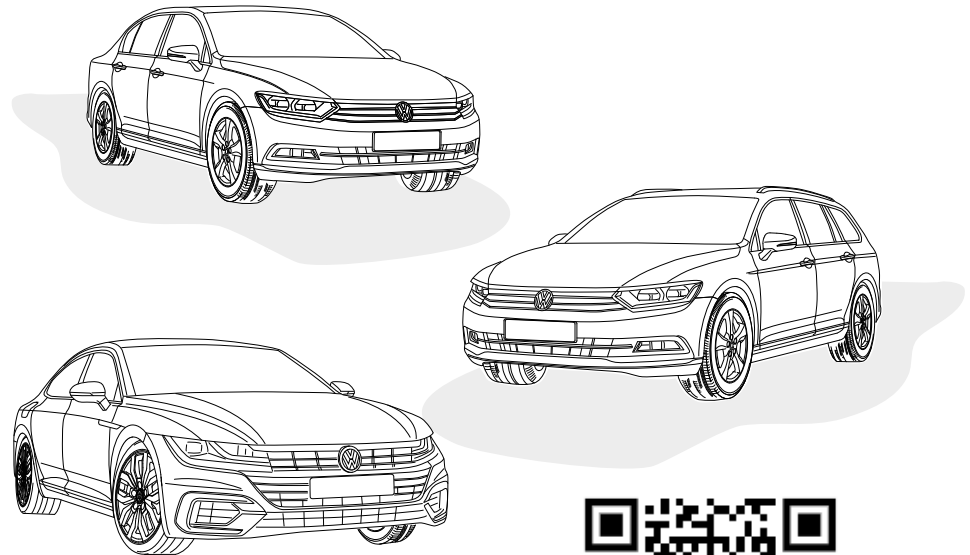
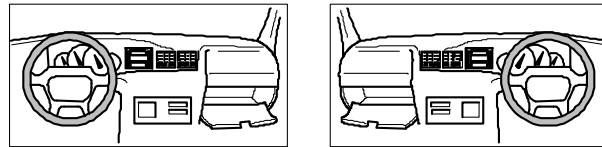

This Fitting Instruction is dated **05-03-2024**.  
Always scan for the latest and most complete fitting instructions.



**BRINK**

Your perfect fit  
brink.eu

# OVERVIEW

For vehicles with trailer preparation

## OPTION 1

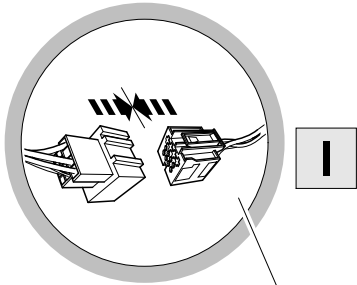

## OPTION 2

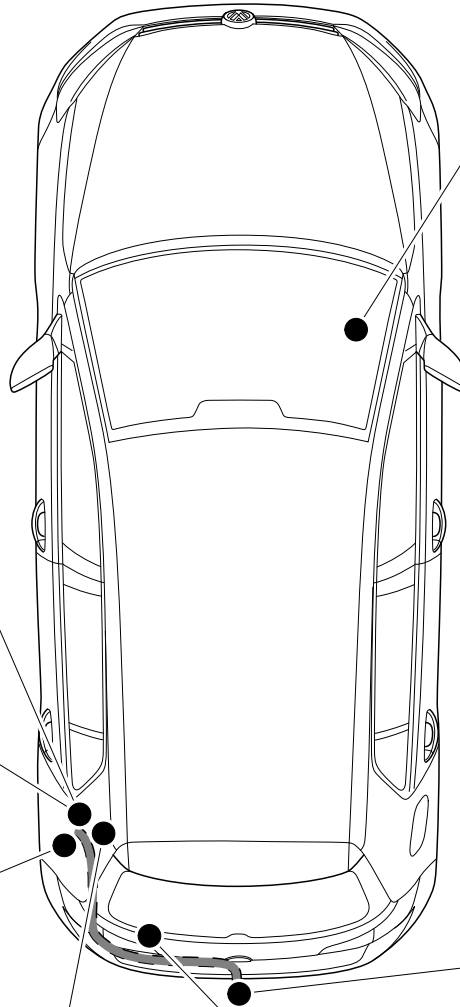
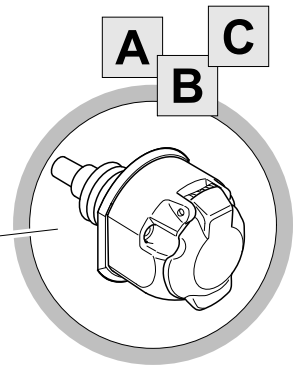
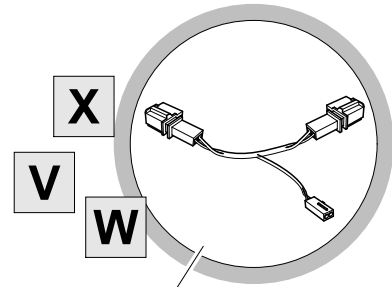
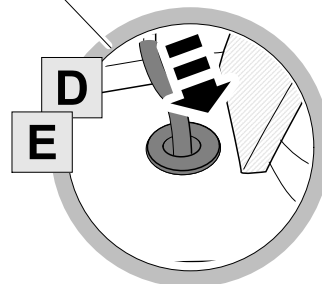
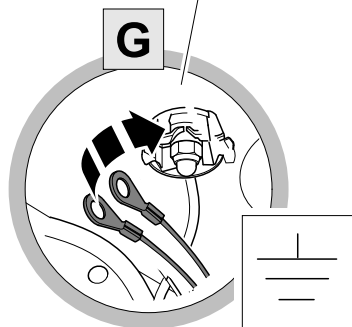
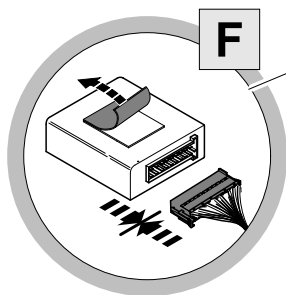
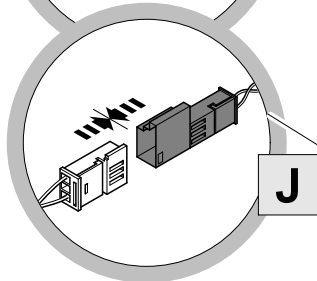
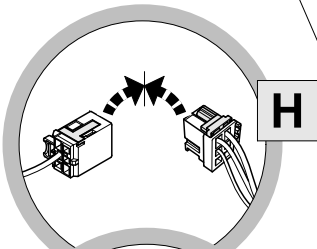

# OVERVIEW

## For vehicles without trailer preparation

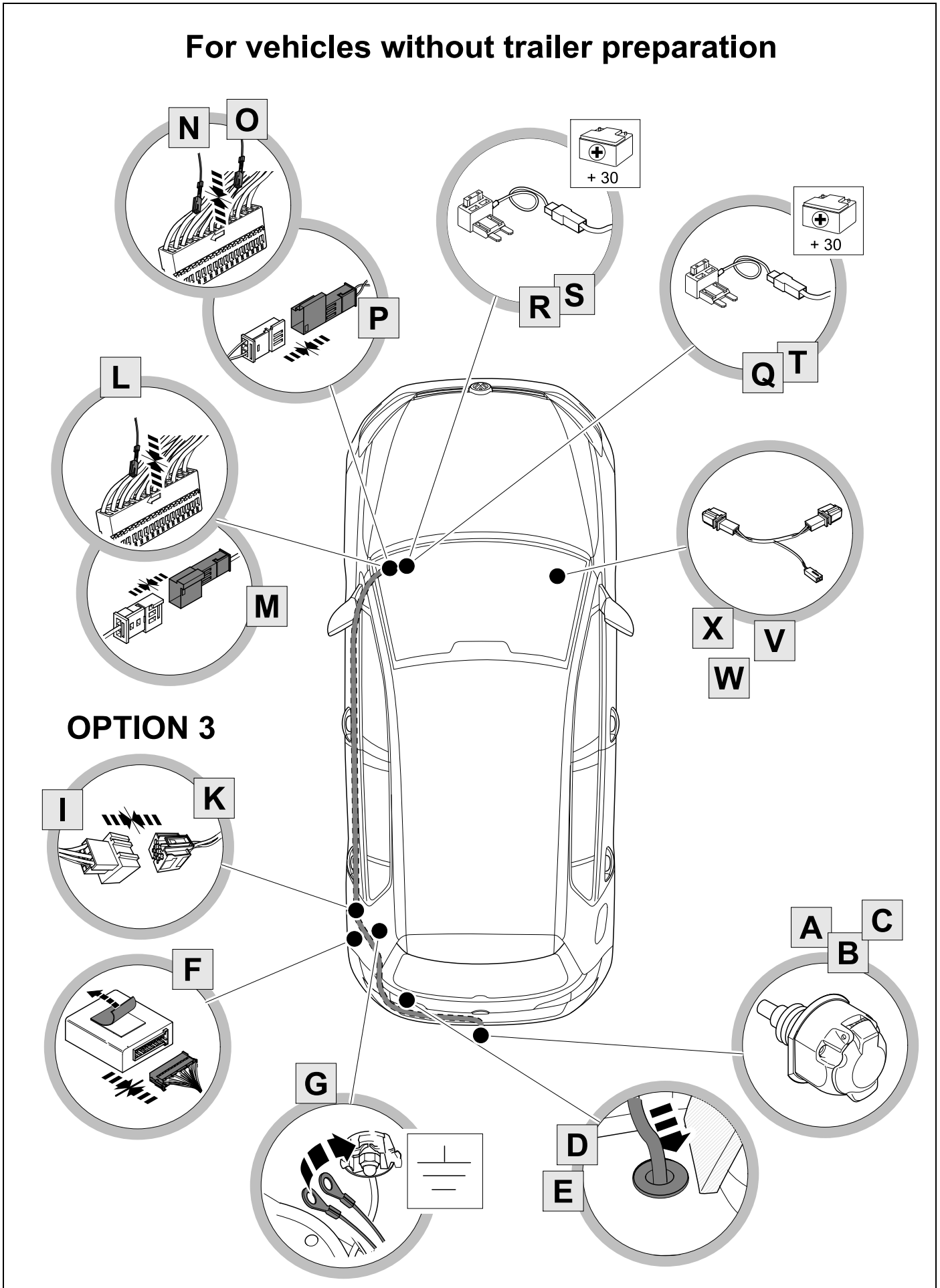

# KIT

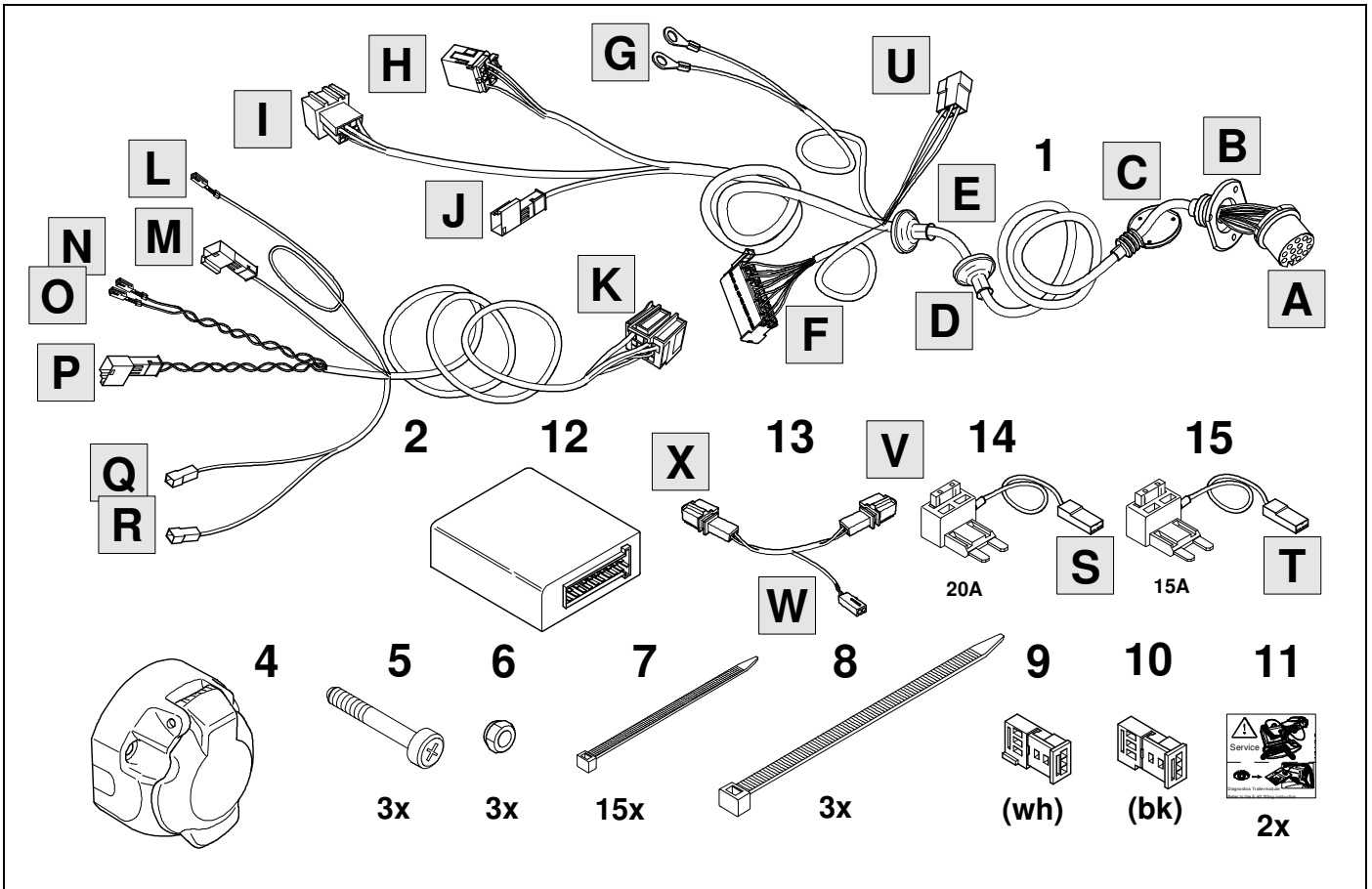

# TOOLS

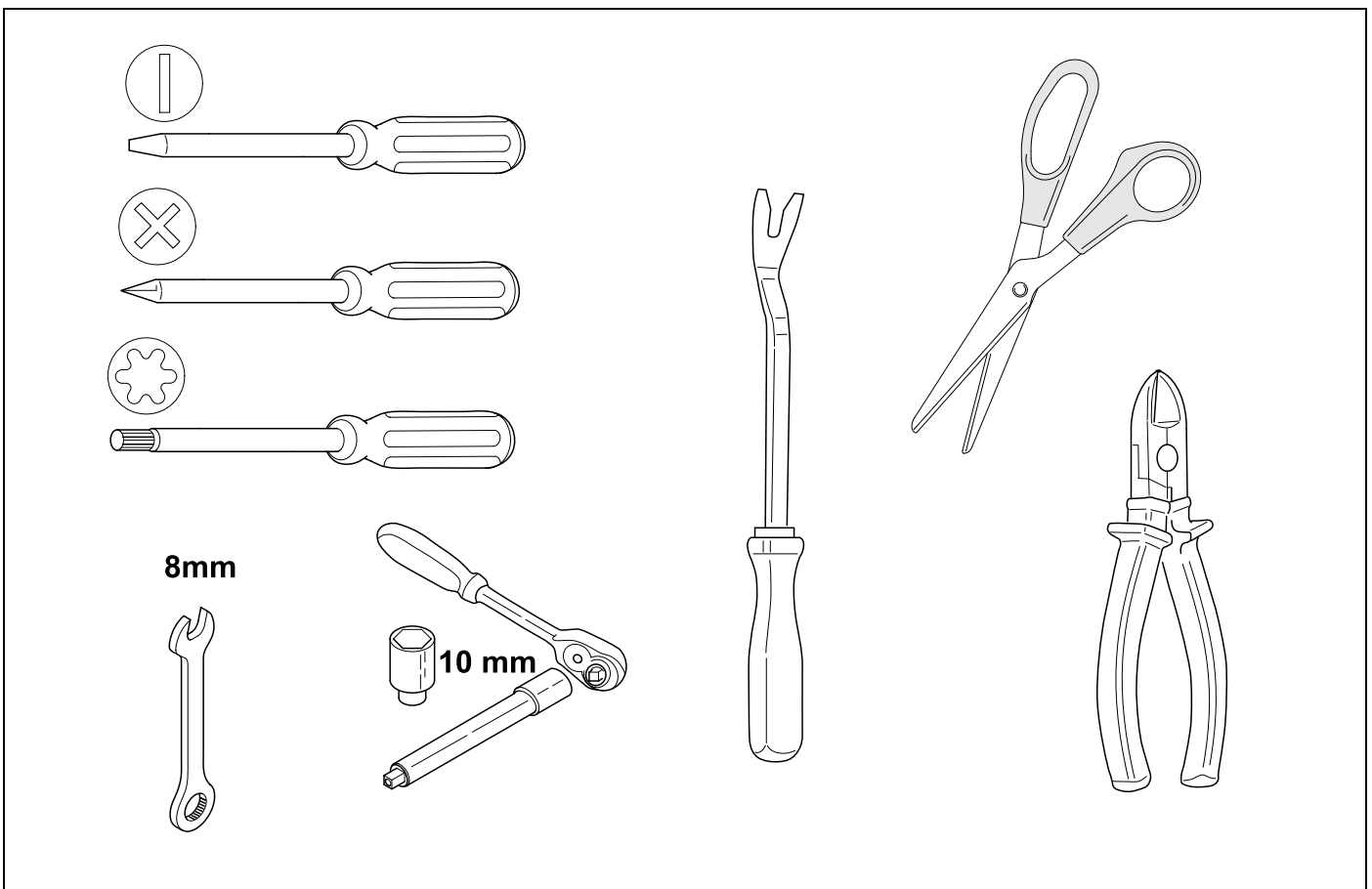

1

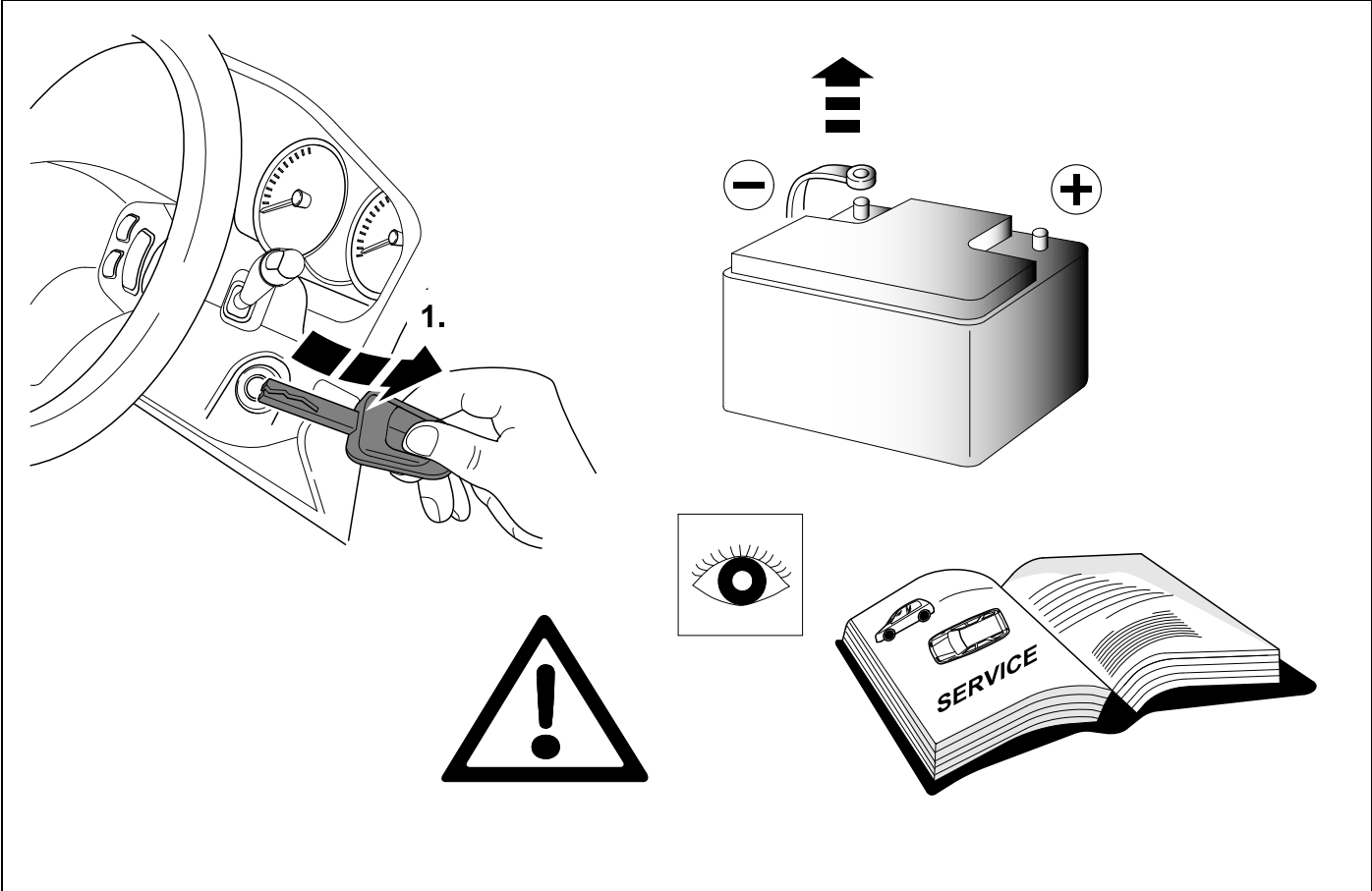

**2**

**REMOVE**

**Passat Variant / Arteon Shooting Brake**

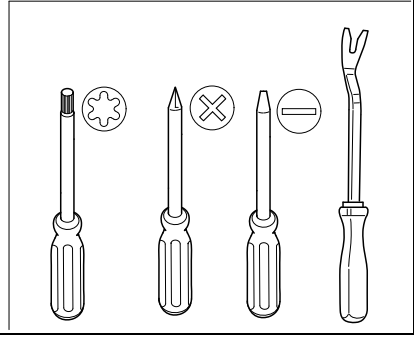
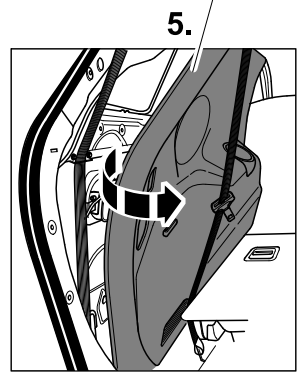
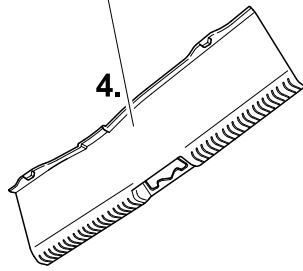
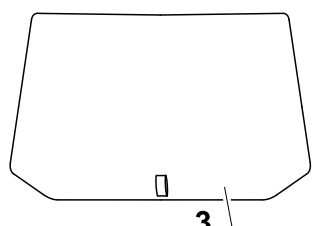
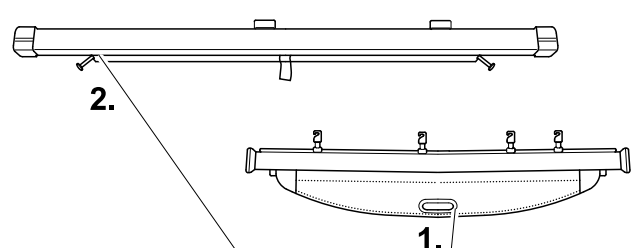
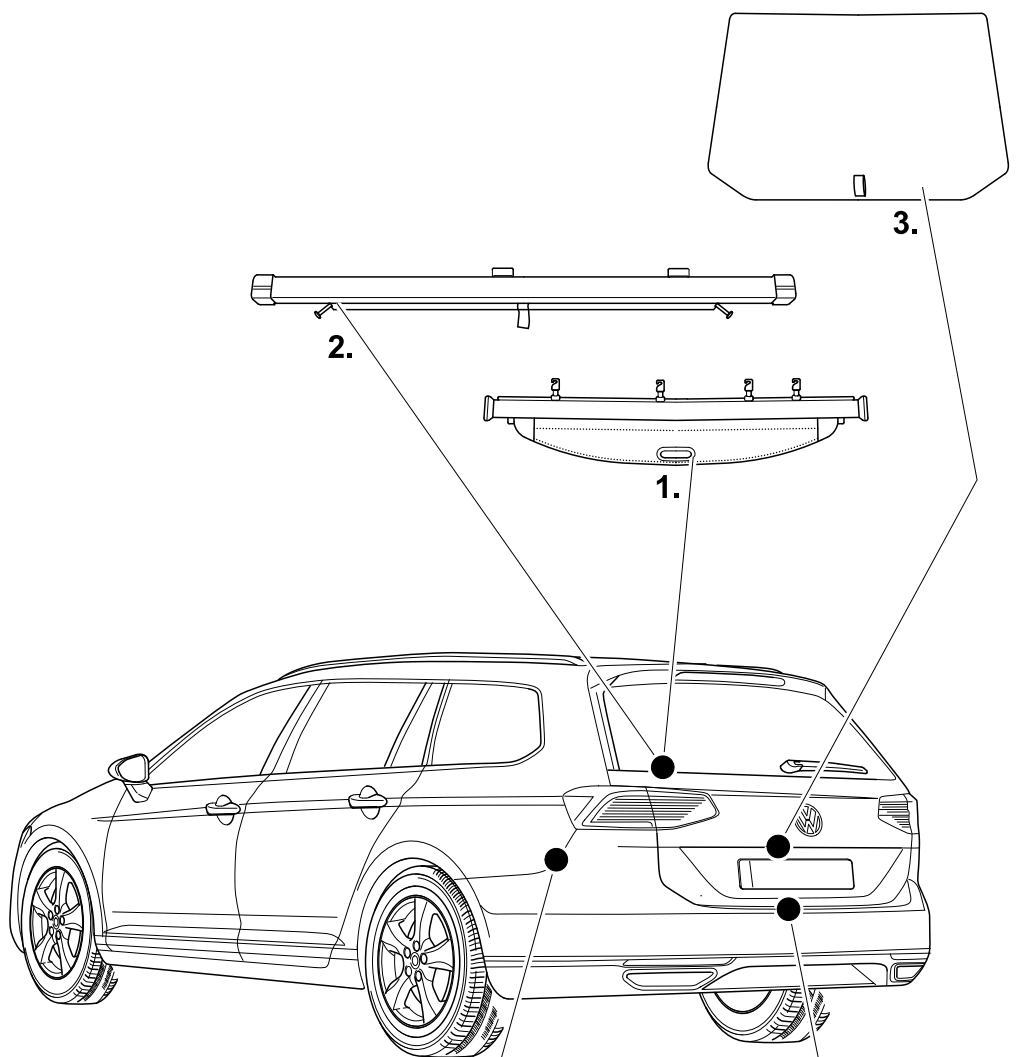

# 3 REMOVE

## Passat Limousine / Arteon

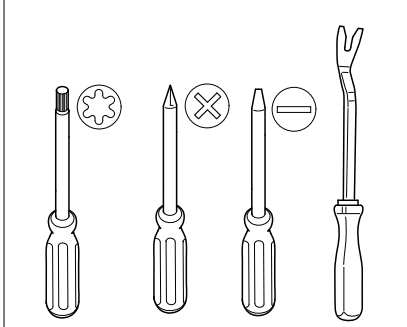
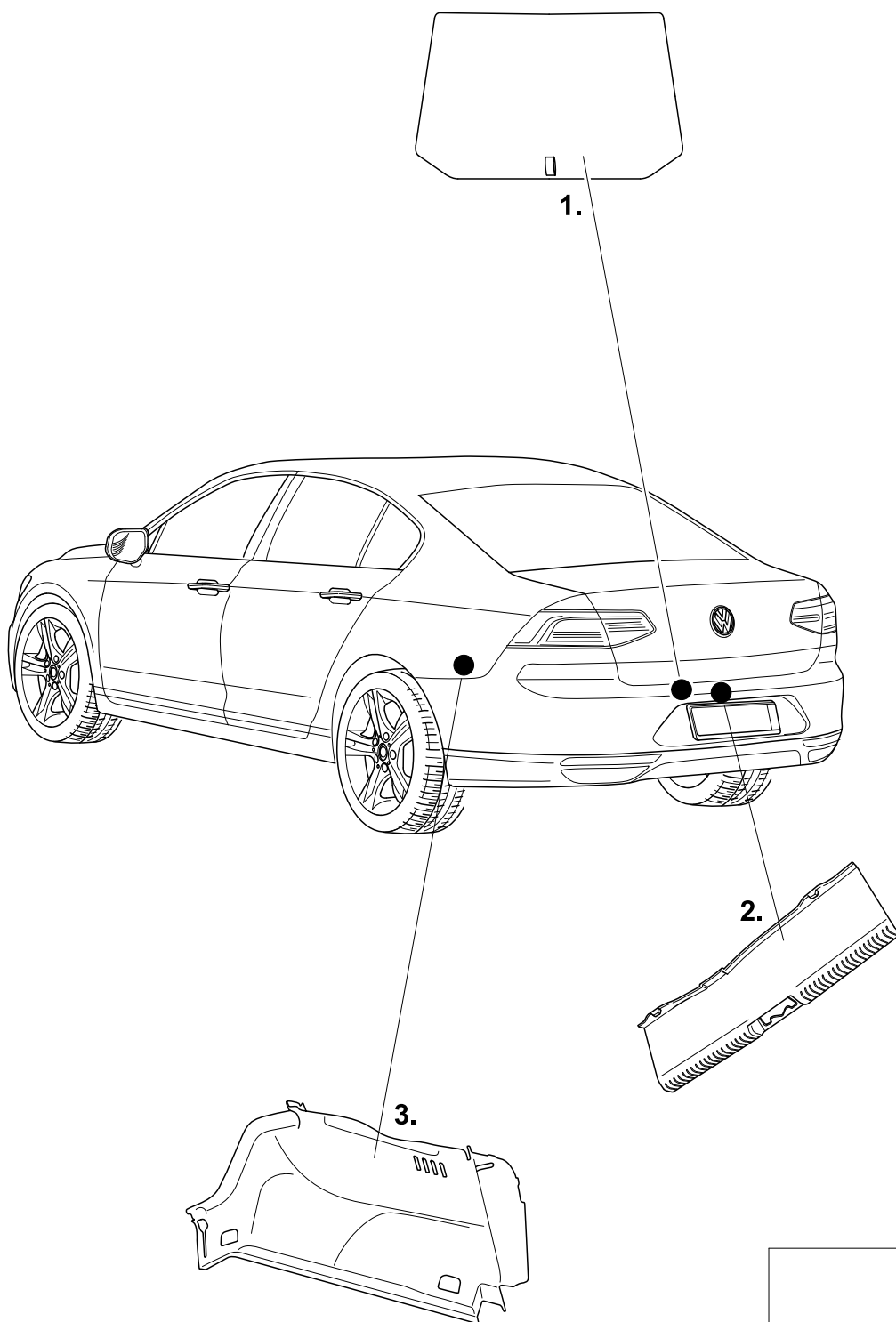

4

# Passat Variant

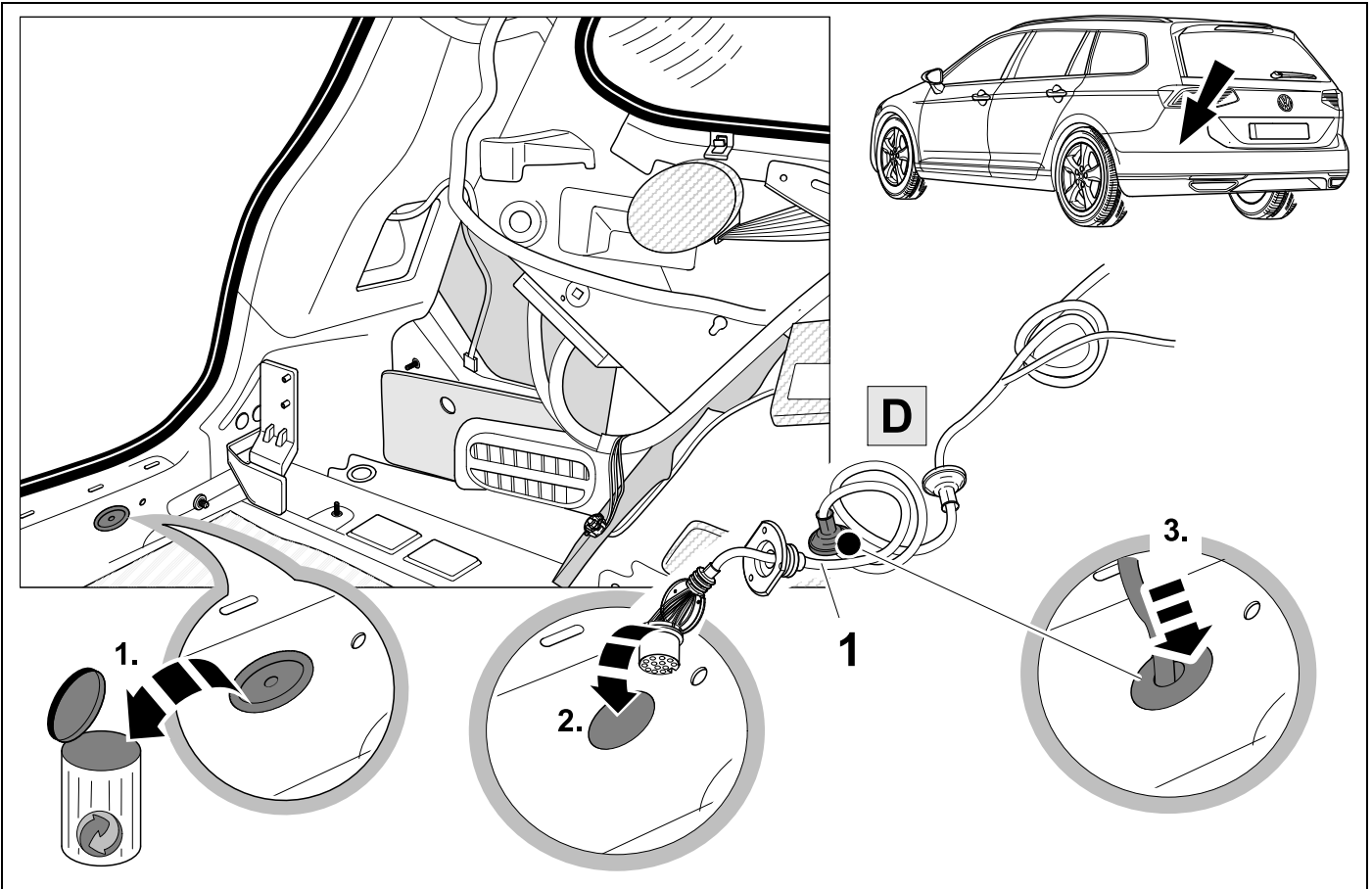

5

# Passat Limousine / Arteon

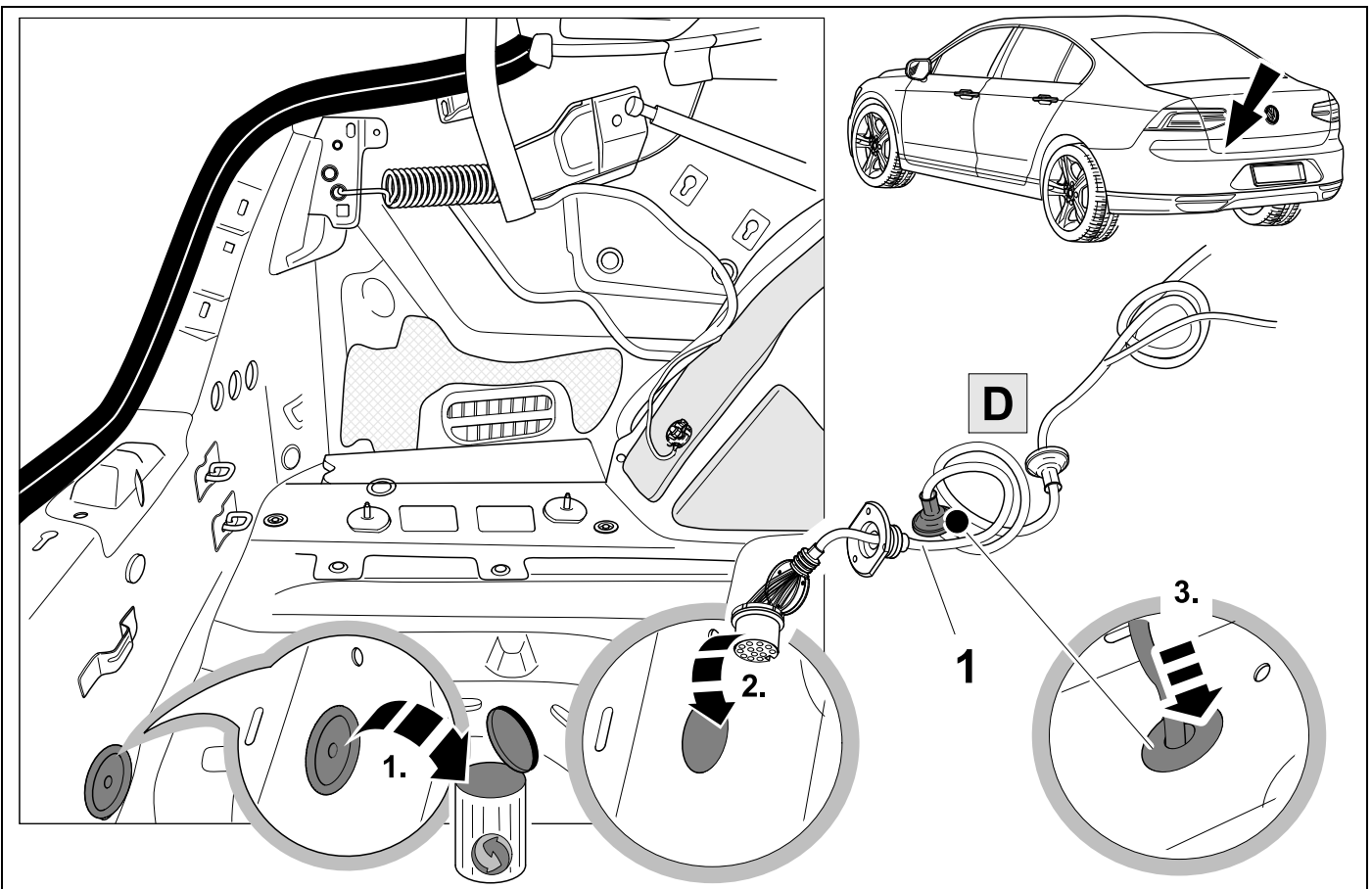



5

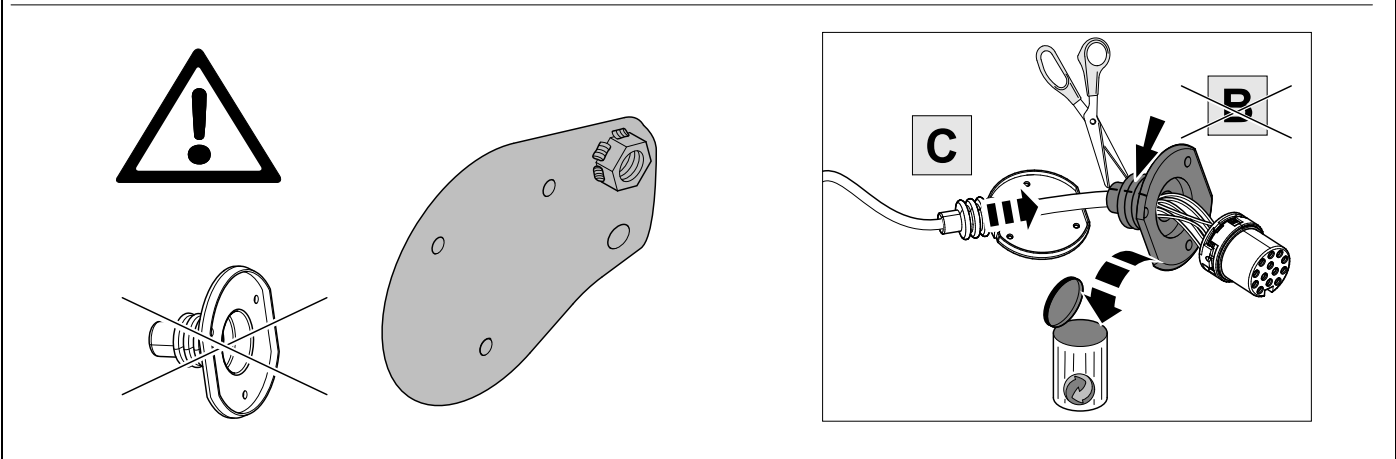
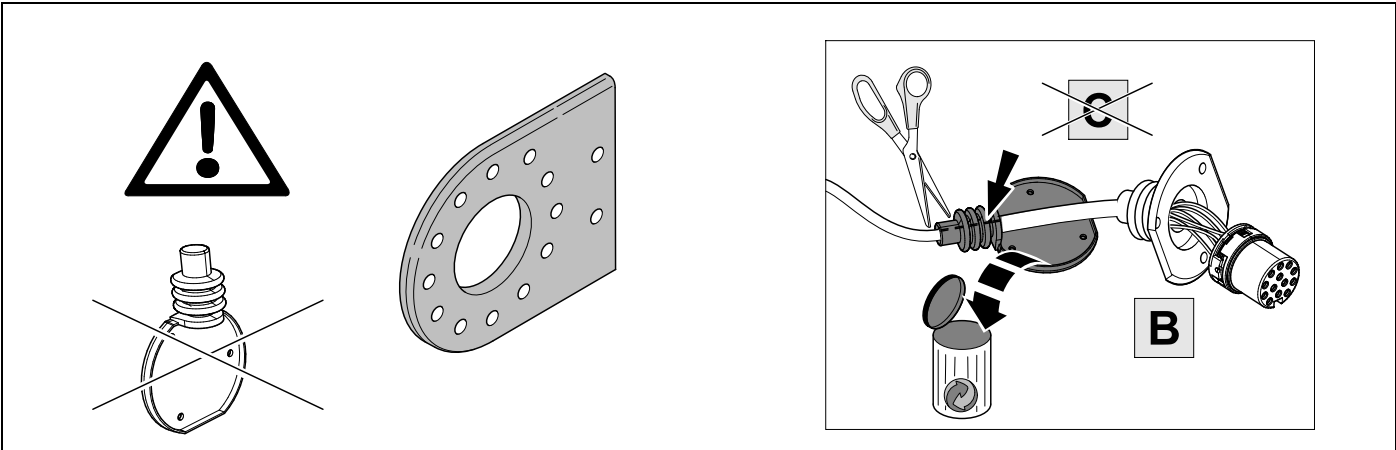

6



8

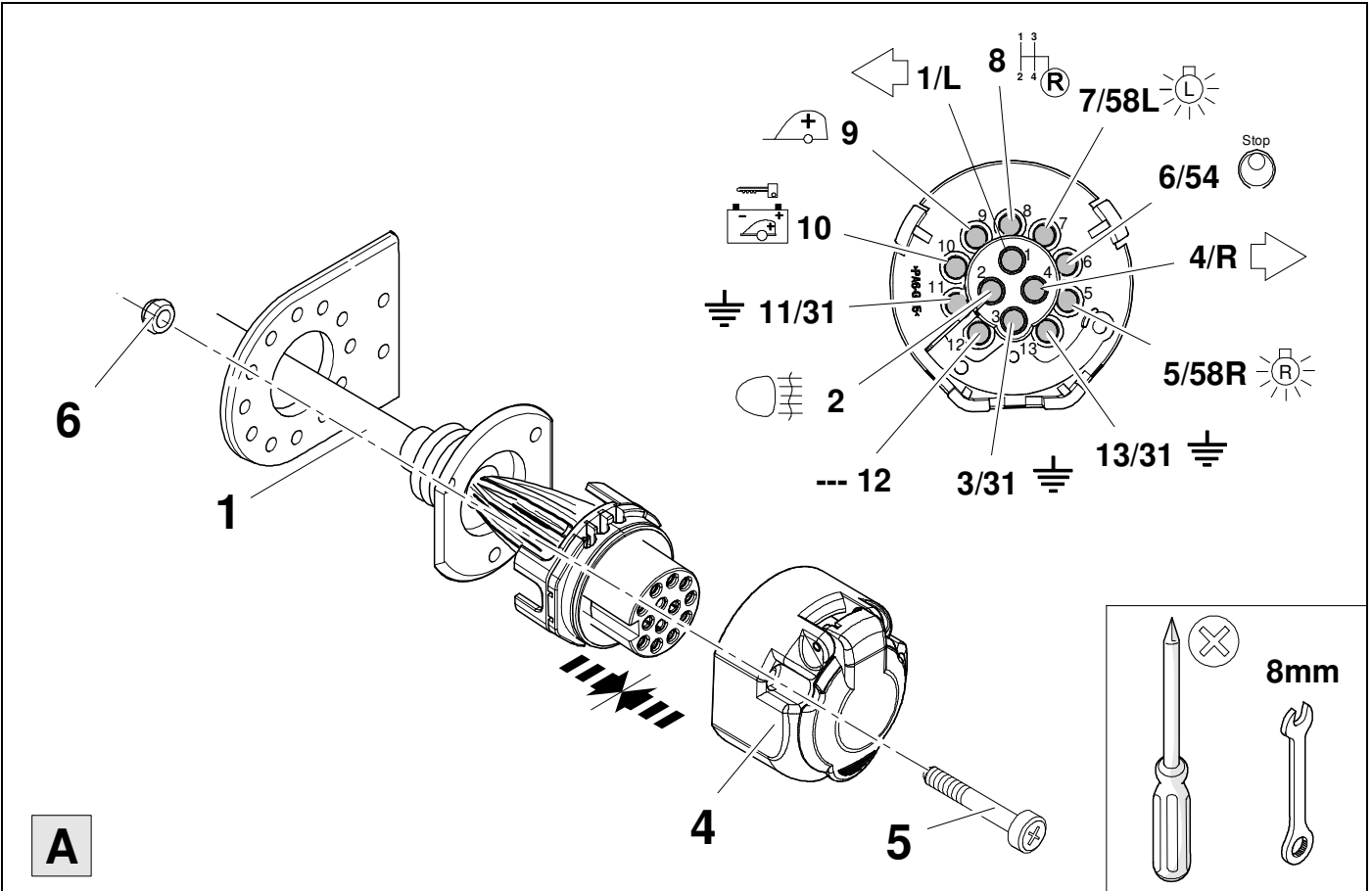

A

7



8

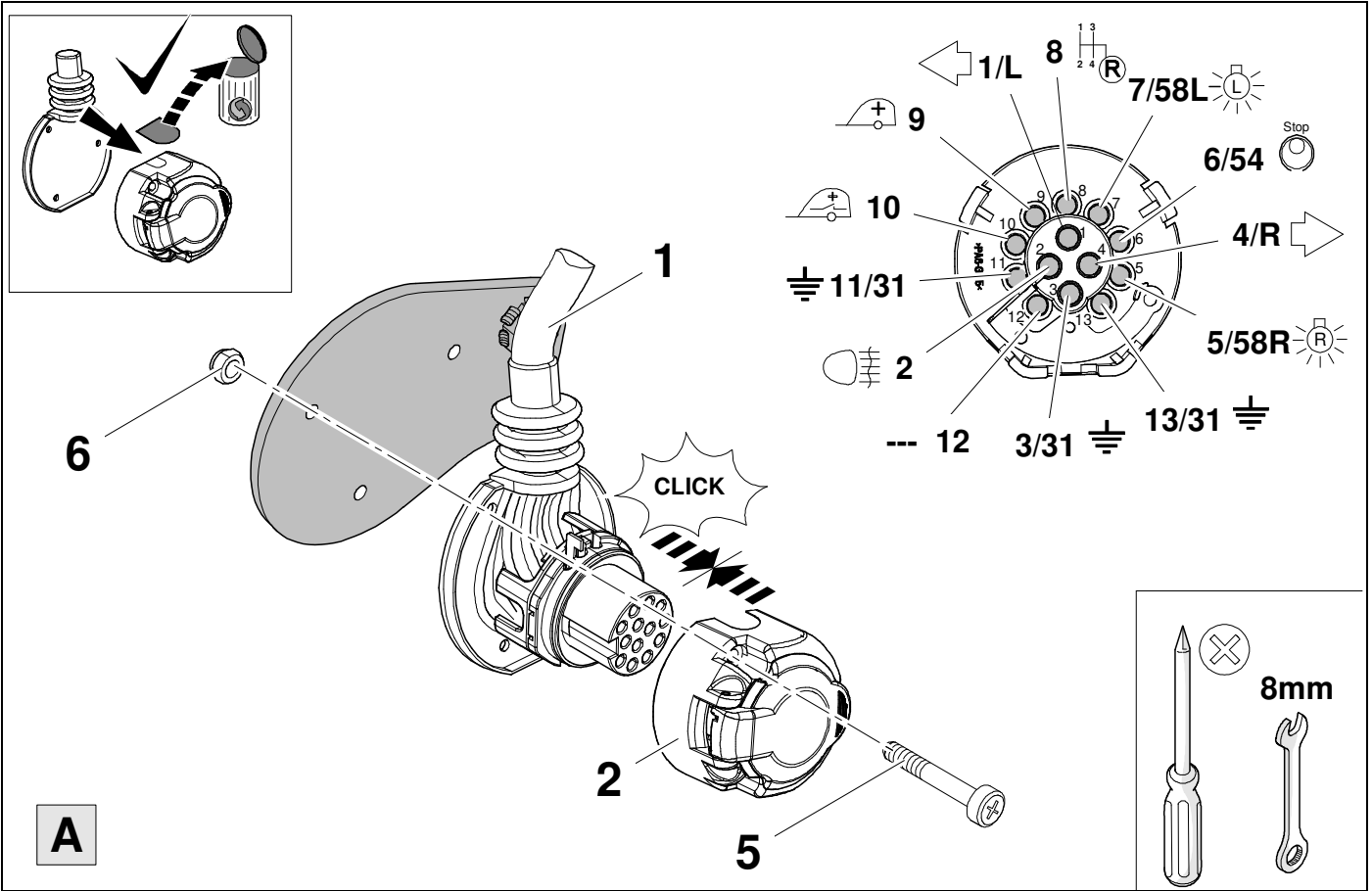

A

8



9

## 13 PIN

1	bk/wh		8	bu/rd	
2	gy		9	rd/bu	
3	wh/bn		10	ye	
4	bk/gn		11	bn/gn	
5	gy/rd		12	no	-/-
6	bk/rd		13	bn	
7	gy/bk				

9	bk	wh	gy	gn	rd	bu	ye	bn	pu	or	no
<b>(D)</b>	schwarz	weiß	grau	grün	rot	blau	gelb	braun	violett	orange	nicht belegt
<b>(GB)</b>	black	white	grey	green	red	blue	yellow	brown	purple	orange	not occupied
<b>(F)</b>	noir	blanc	gris	vert	rouge	bleu	jaune	brun	violet	orange	inutilisé
<b>(NL)</b>	zwart	wit	grijs	groen	rood	blauw	geel	bruin	violet	oranje	niet aangesloten
<b>(DK)</b>	sort	hvid	grå	grøn	rød	blå	gul	brun	violet	orange	ikke anvendt
<b>(N)</b>	svart	hvit	grå	grønn	rød	blå	gul	brun	fiolett	oransje	ikke i bruk
<b>(S)</b>	svart	vit	grå	grön	röd	blå	gul	brun	violett	orange	ej använd
<b>(FIN)</b>	musta	valkoinen	harmaa	vihreä	punainen	sininen	keltainen	ruskea	violetti	oranssi	ei varattu
<b>(I)</b>	nero	bianco	grigio	verde	rosso	blu	giallo	marrone	viola	arancione	libero
<b>(E)</b>	negro	blanco	gris	verde	rojo	azul	amarillo	marrón	violeta	anaranja-do	no ocupado
<b>(P)</b>	preto	branco	cinzento	verde	vermelho	azul	amarelo	castanho	violeta	laranja	não ocupado
<b>(GR)</b>	μαύρος	λευκός	Γκρι	πράσινος	κόκκινος	μπλε	κίτρινος	καφέ	Μωβ	πορτοκαλί	δεν είναι κατ εισημμένος
<b>(PL)</b>	czarny	biały	szaro	zielony	czerwony	niebiesko	żółty	brazowy	fioletowy	pomarańczowy	wolny
<b>(CZ)</b>	černý	bílý	šedý	zelený	červený	modrý	žlutý	hnědý	fialový	oranžový	neobsazen
<b>(TR)</b>	siyah	beyaz	gri	yeşil	kırmızı	mavi	sarı	kahverengi	mor	portakal rengi	boş
<b>(H)</b>	fekete	fehér	szürke	zöld	piros	kék	sárga	barna	ibolyakék	narancssárga	nem foglalt
<b>(HR)</b>	crno	bijelo	sivo	zeleno	crveno	plavo	zuto	smeđe	ljubičasto	narandasto	nije zauzeto
<b>(BUL)</b>	черен	бял	сив	зелен	червен	син	жълт	кафяв	виолетов	оранжев	свободно
<b>(RO)</b>	negru	alb	gri	verde	roșu	albastru	galben	maro	violet	portocaliu	liber
<b>(RU)</b>	черный	белый	серый	зеленый	красный	голубой	жёлтый	коричневый	пурпурный	оранжевый	свободно
<b>(LT)</b>	juoda	balta	pilka	žalia	raudona	mėlyna	geltona	ruda	purpurinė	oranžinė	laisva
<b>(LV)</b>	melna	balta	pelēka	zaļa	sarkana	zila	dzeltena	brūna	purpur-sarkana	oranža	brīvs
<b>(EST)</b>	must	valge	hall	roheline	punane	sinine	kollane	pruun	purpur-punane	oraanž	vaba
<b>(SLO)</b>	črna	bela	siva	zelena	rdeča	modra	rumena	smeđ	vijoličast	oranžen	ni zasedeno
<b>(SK)</b>	čierny	biely	šedý	zelený	červený	modrý	žltý	hnědý	fialový	pomaraňový	neobsadený

10

# Passat Variant

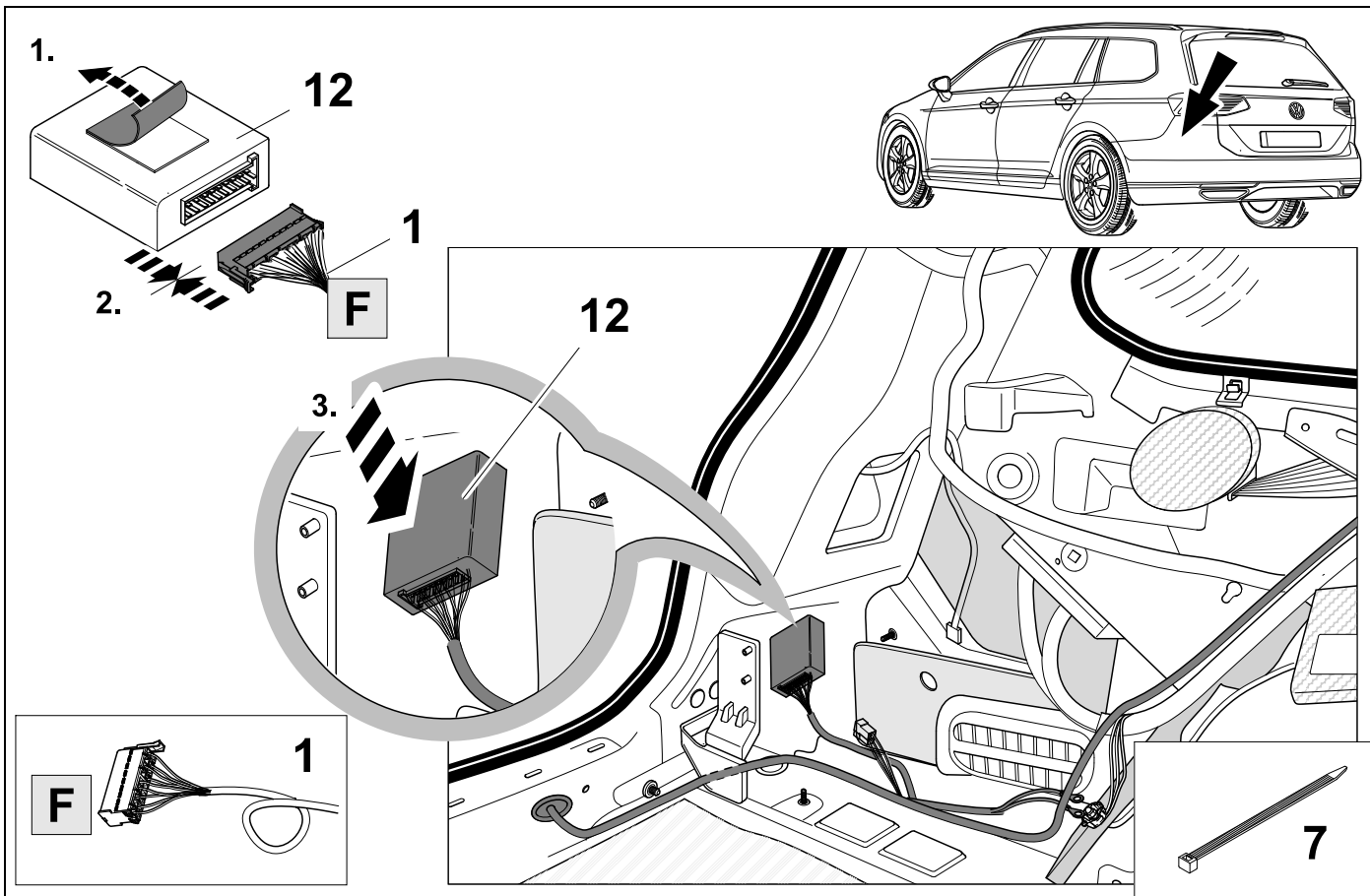

11

# Passat Variant

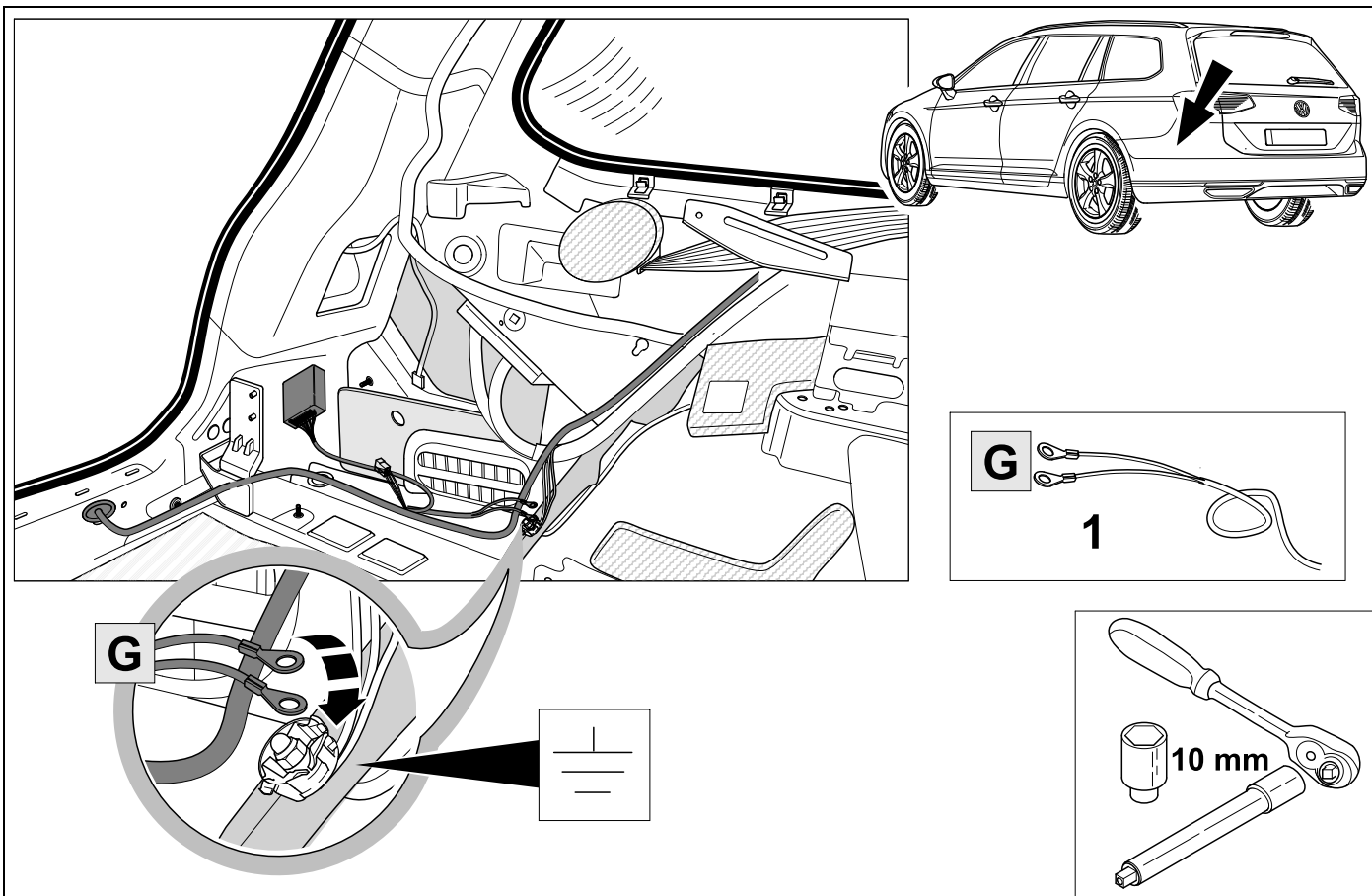

12

# Passat Limousine / Arteon

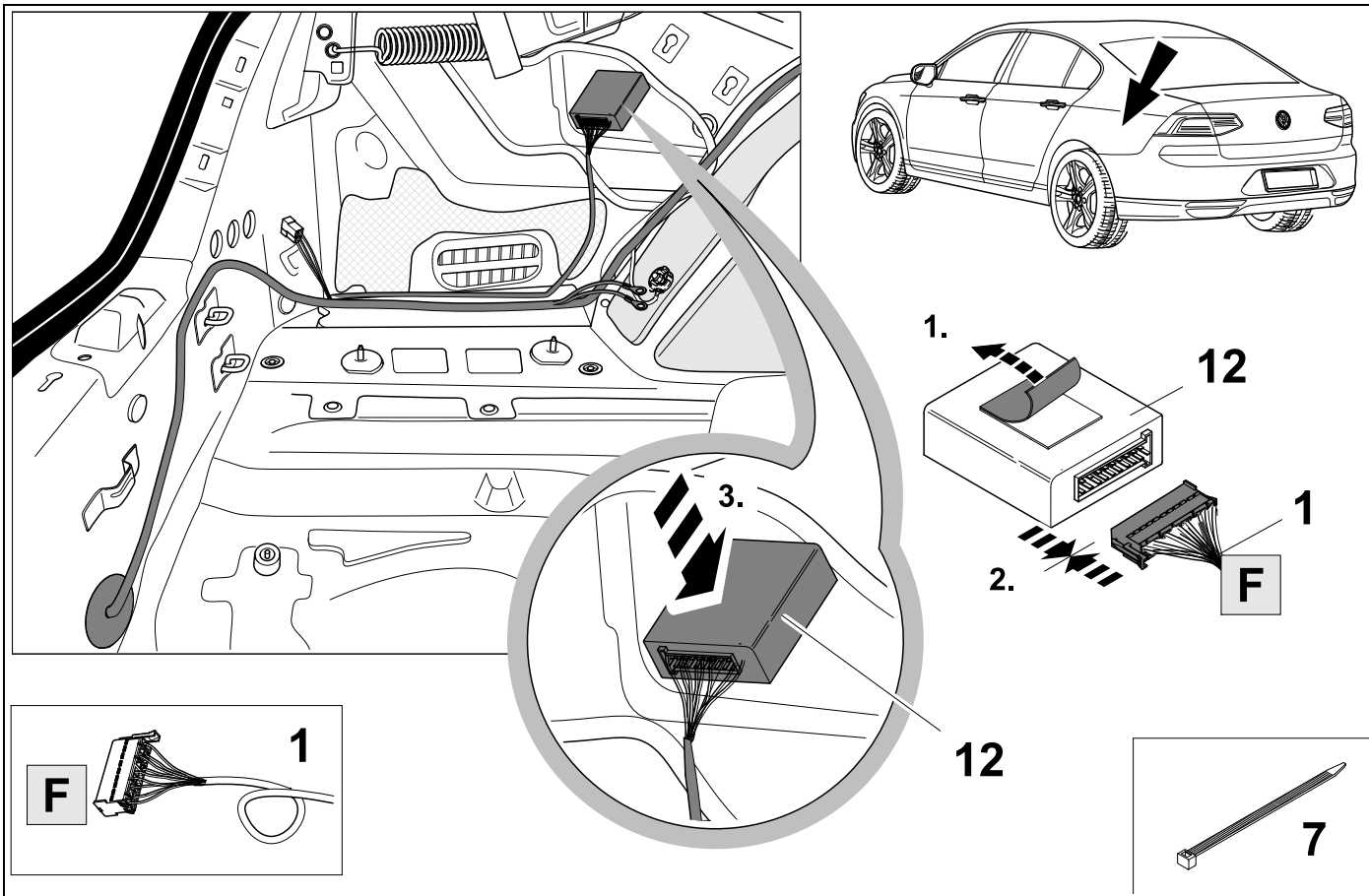

13

# Passat Limousine / Arteon

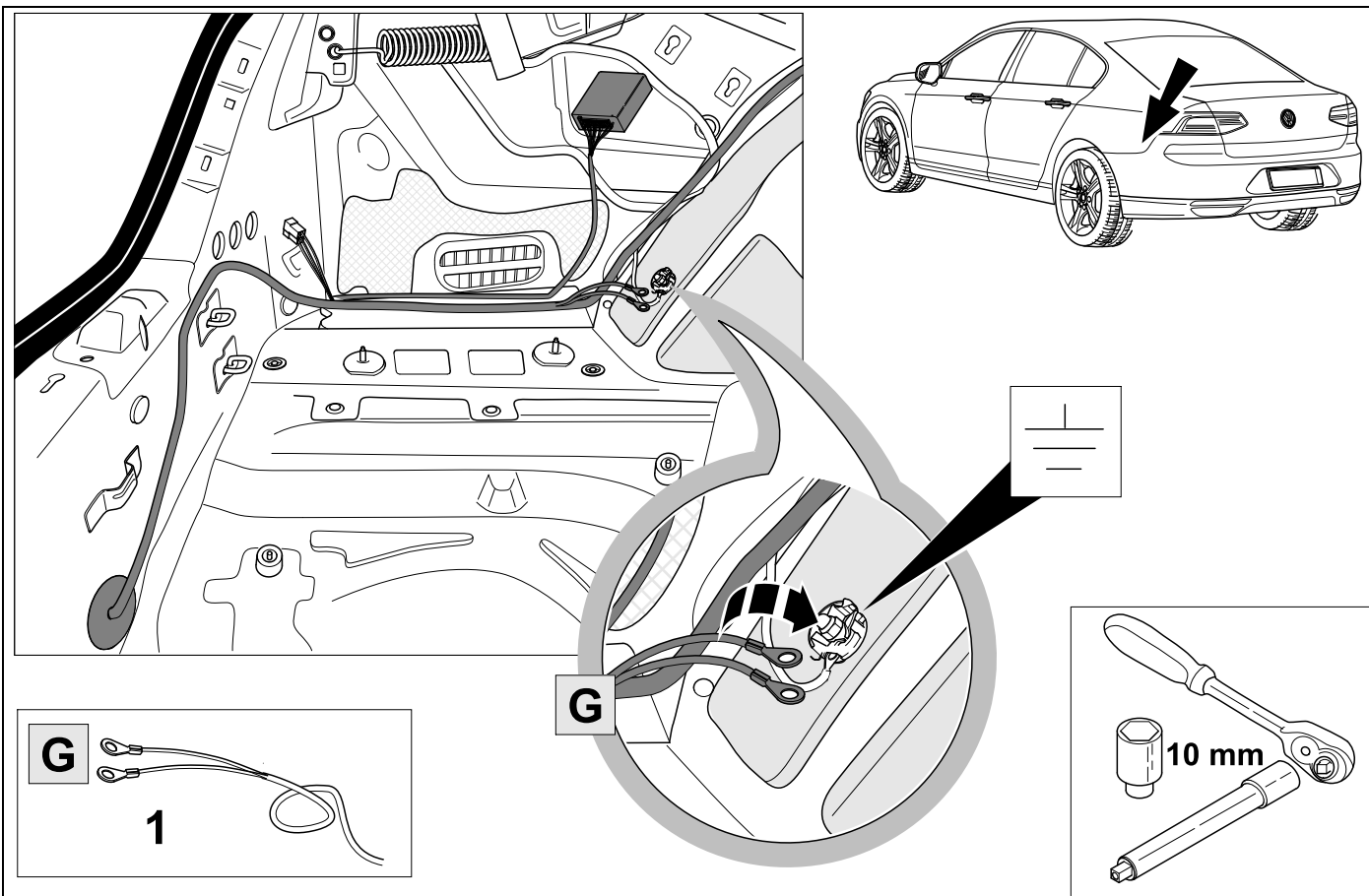

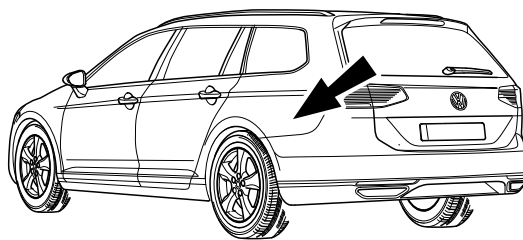
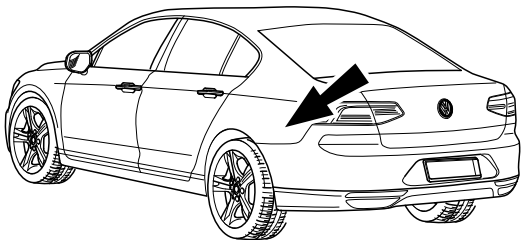

**Vehicles with trailer preparation >> 05/14**

**OPTION 1**

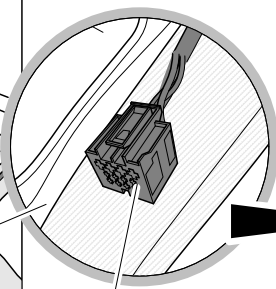
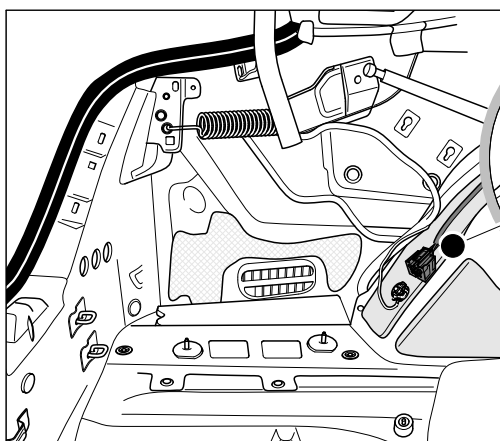

rd  
12 PIN

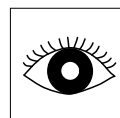

15	⇒	16
24	⇒	26
46	⇒	62

**Vehicles with trailer preparation 06/14 >>**

**OPTION 2**

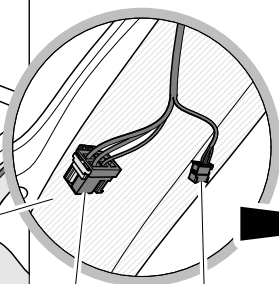
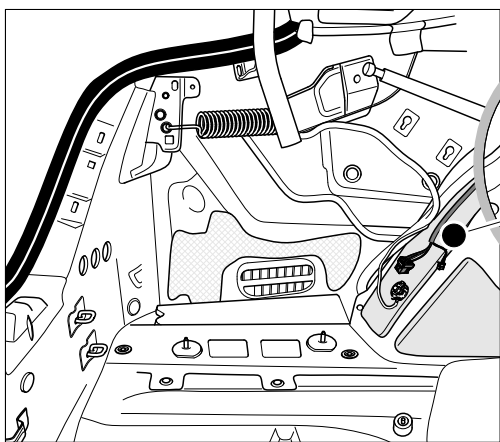

bk 6 PIN      bk 10 PIN

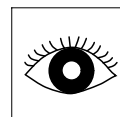

17	⇒	26
46	⇒	62

**Vehicles without trailer preparation**

**OPTION 3**

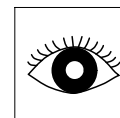
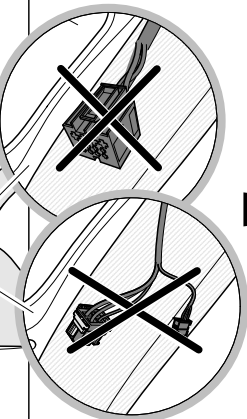
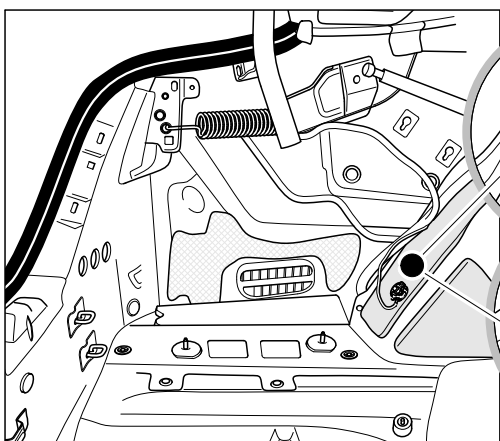

27	⇒	62
----	---	----

15



9

OPTION 1

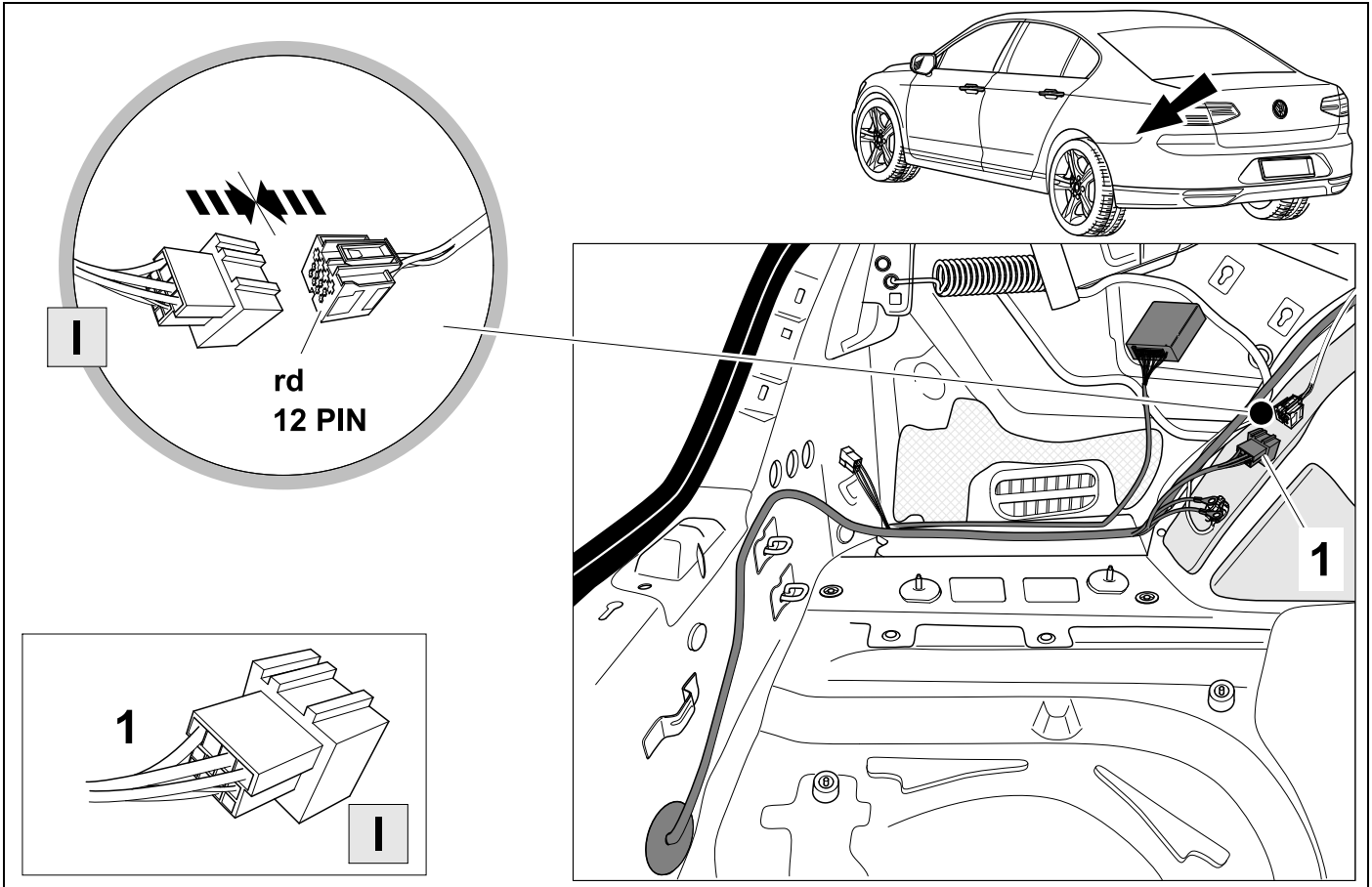

16



9

OPTION 1

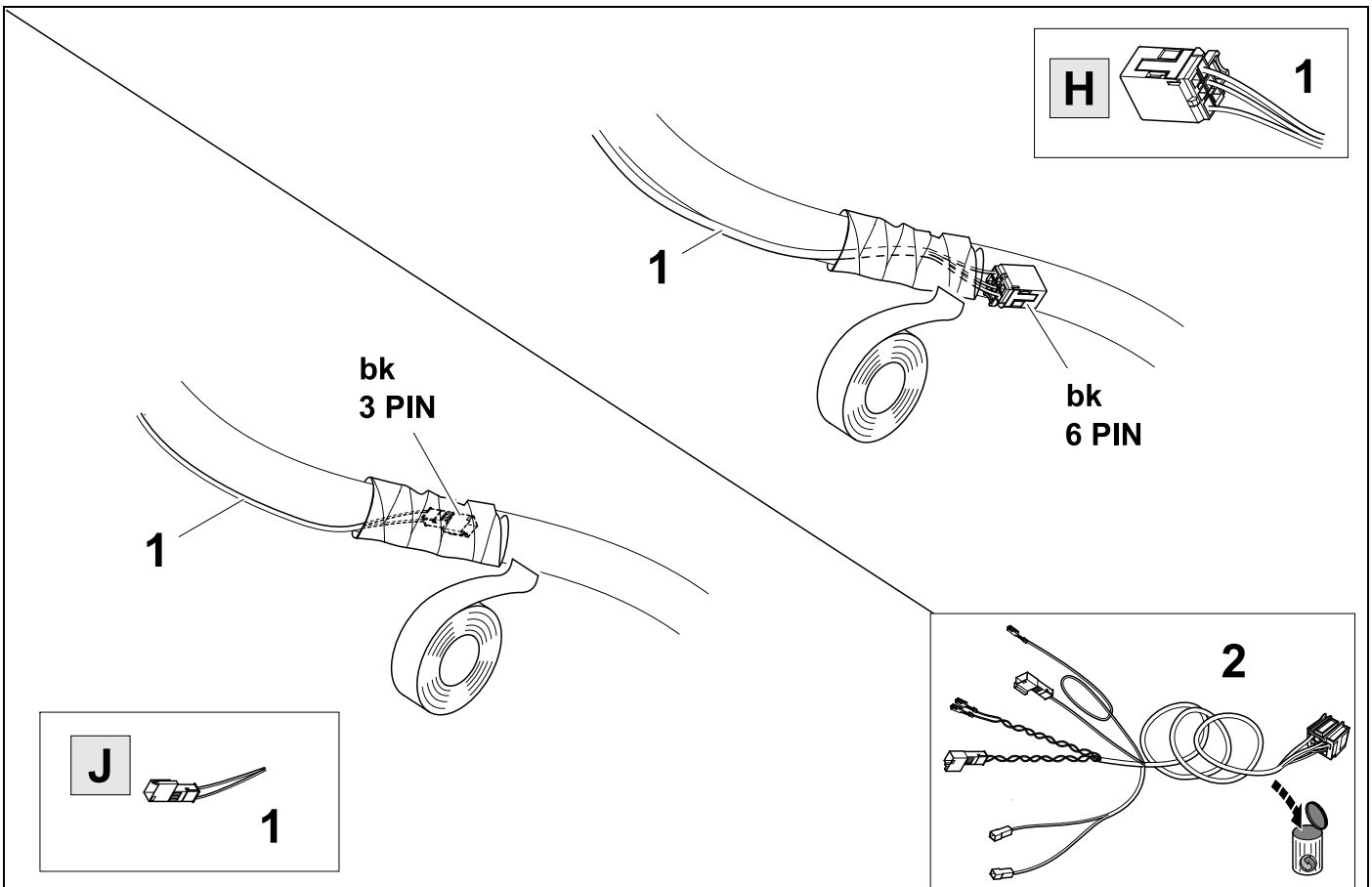

17



OPTION 2

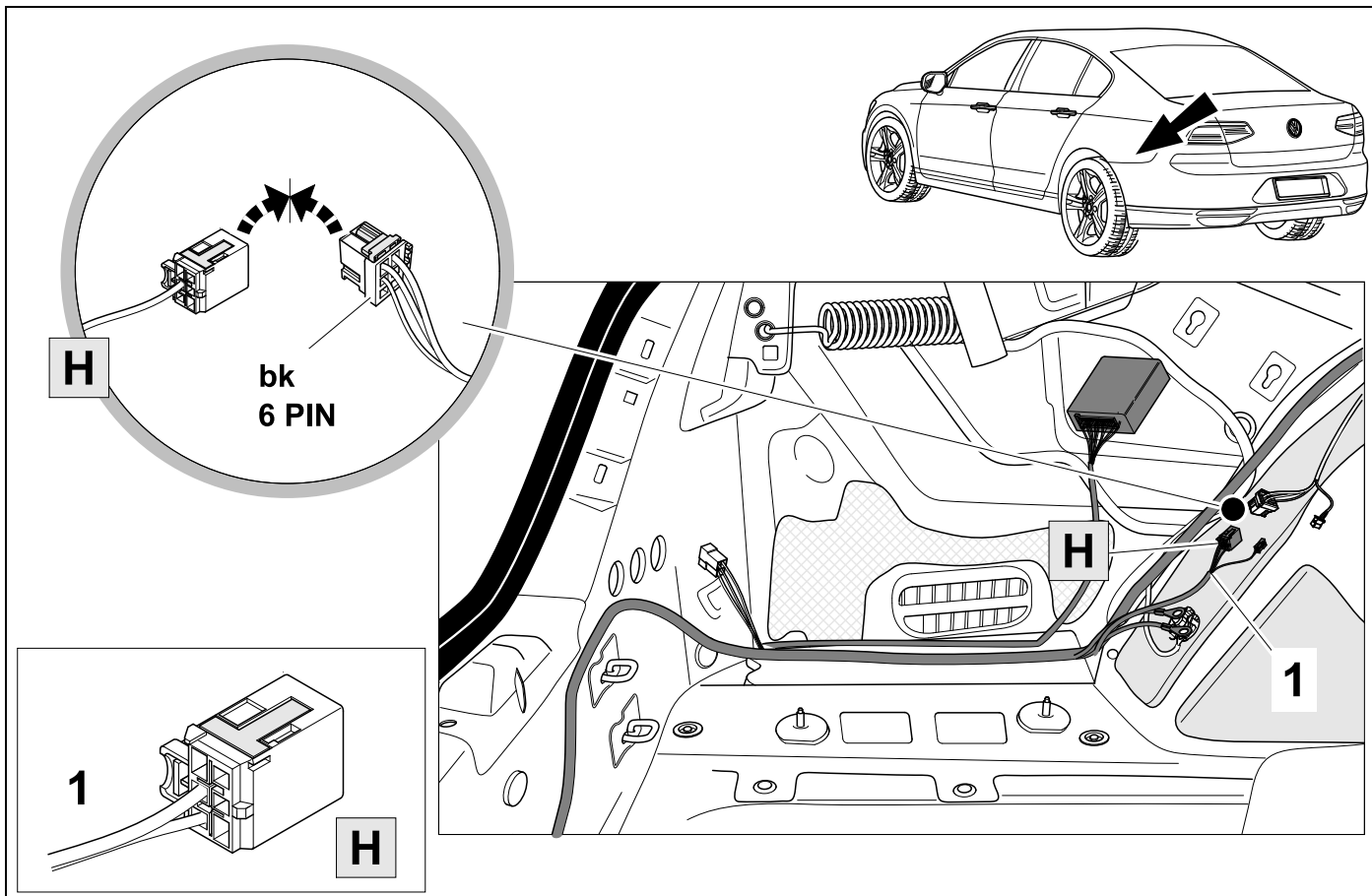

18 Passat / Arteon



OPTION 2

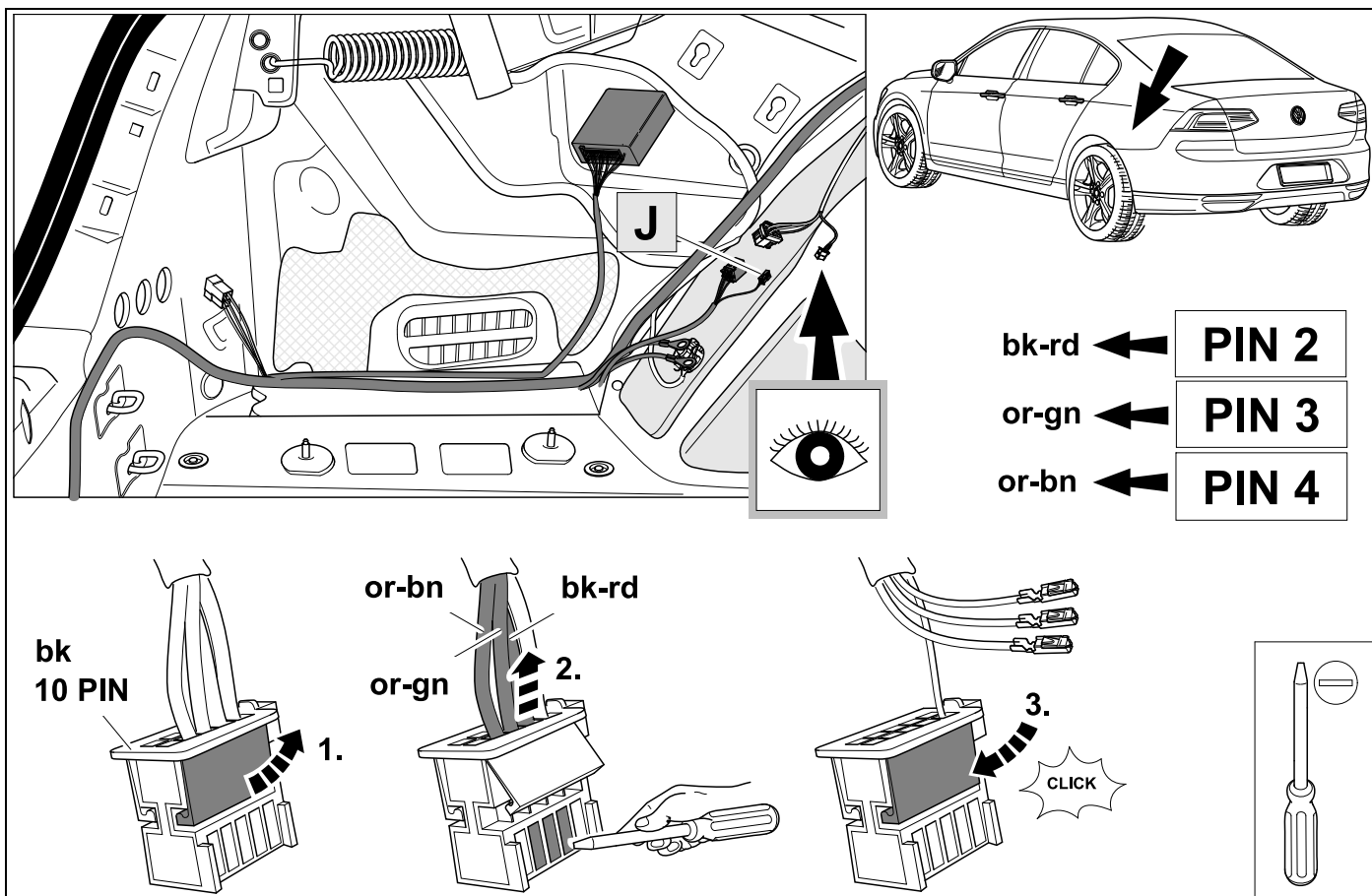



19 Arteon Shooting Brake



9

OPTION 2

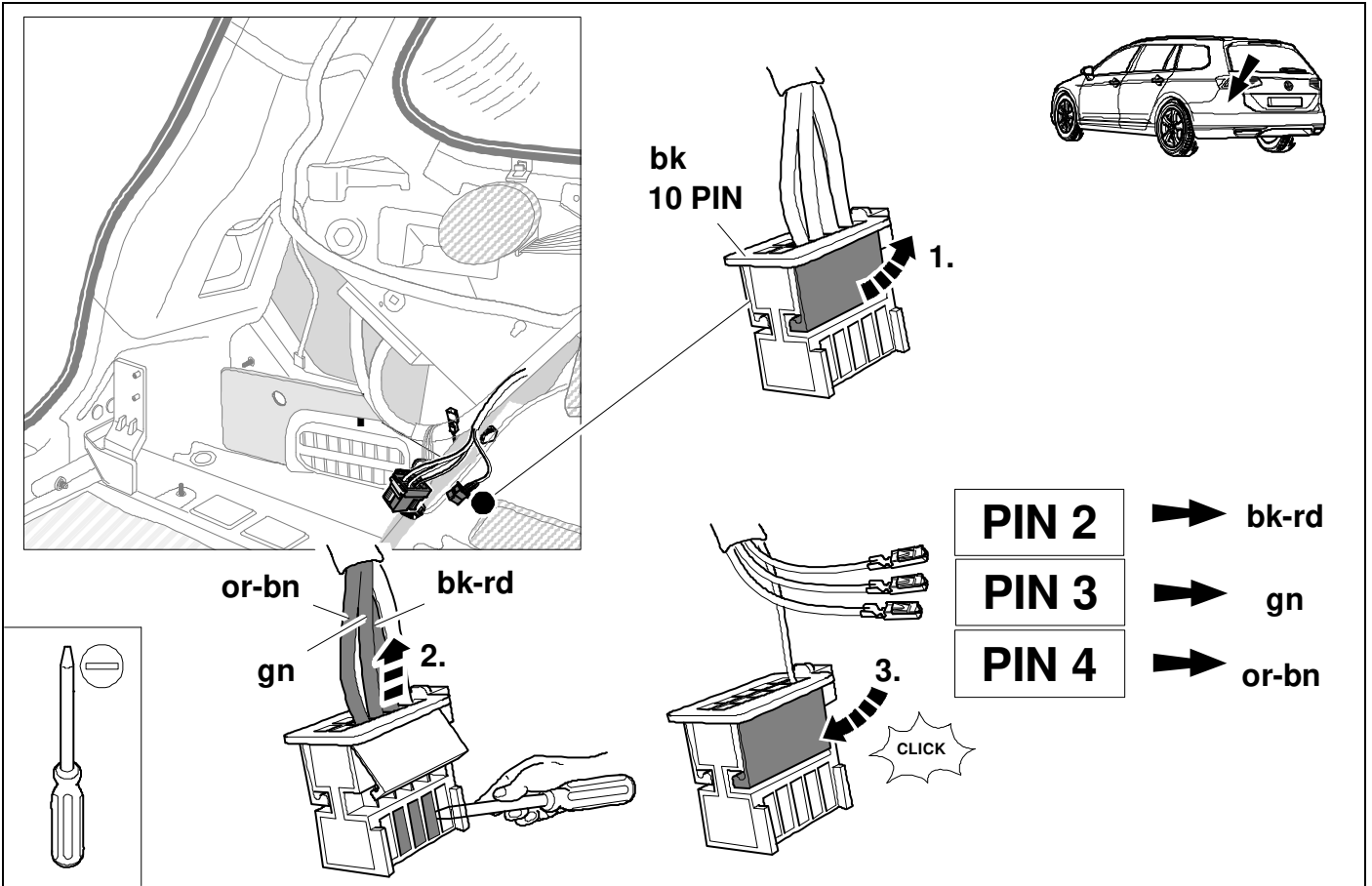

20



9

OPTION 2

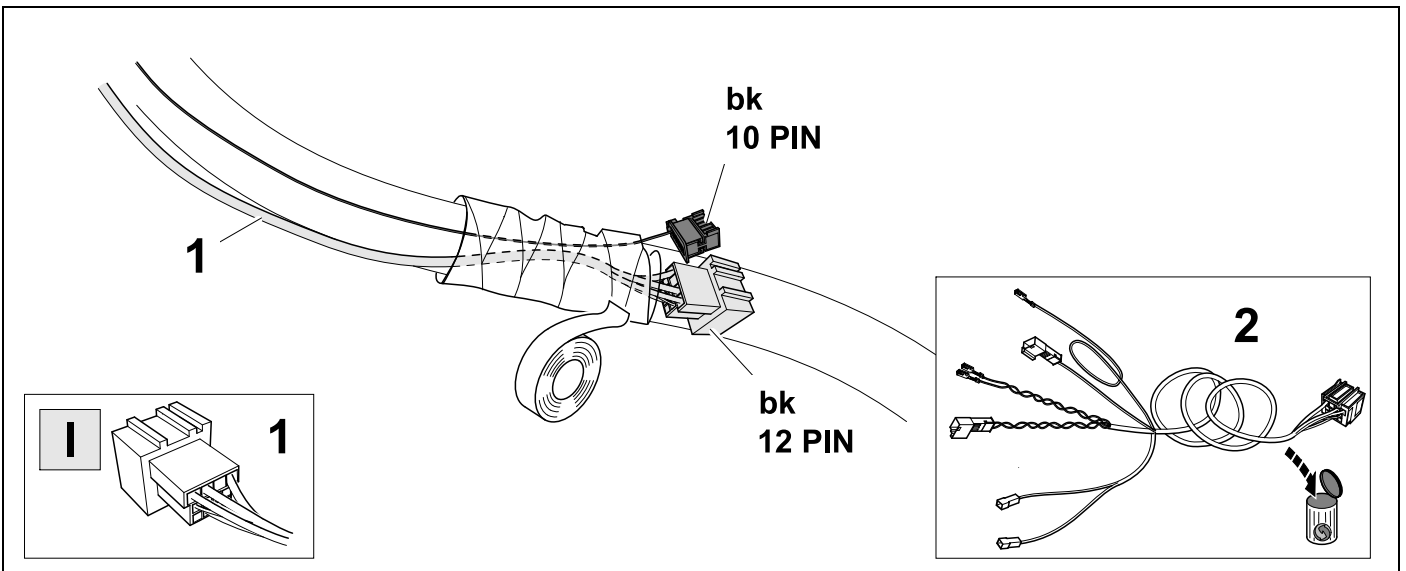

21 Passat / Arteon



9

OPTION 2

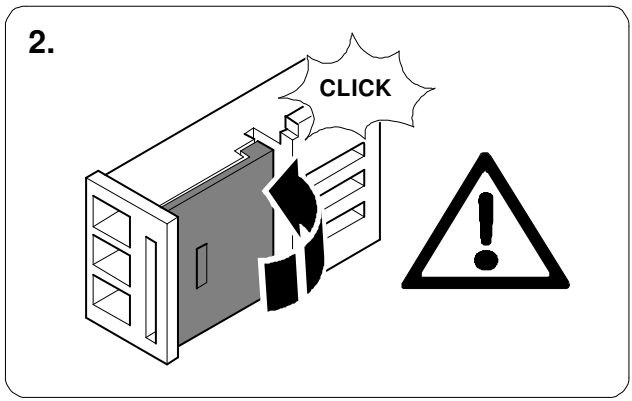
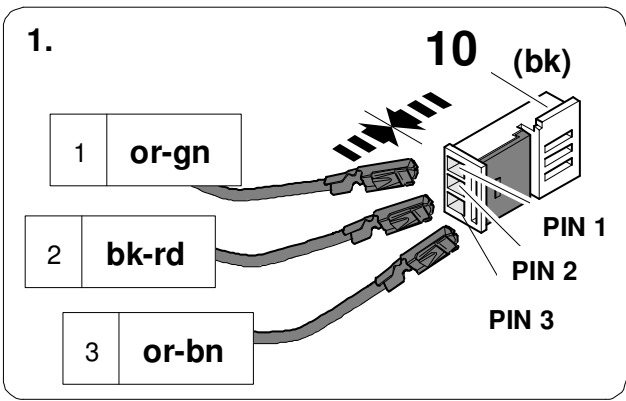

22 Arteon Shooting Brake



9

OPTION 2

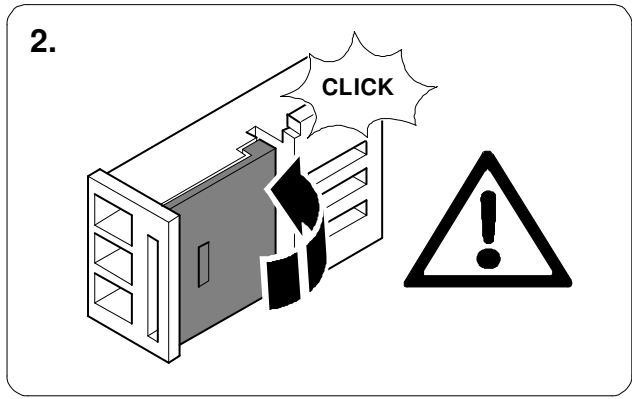
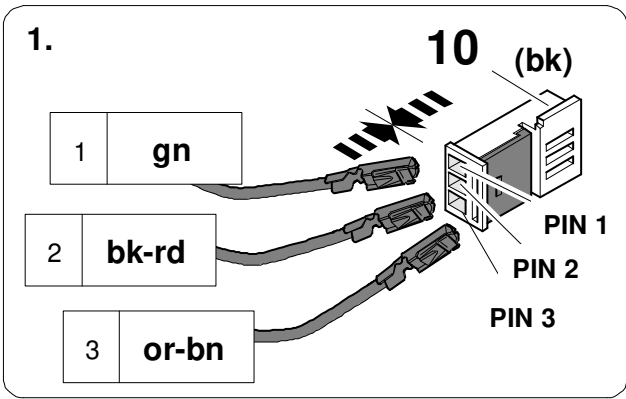

23

OPTION 2

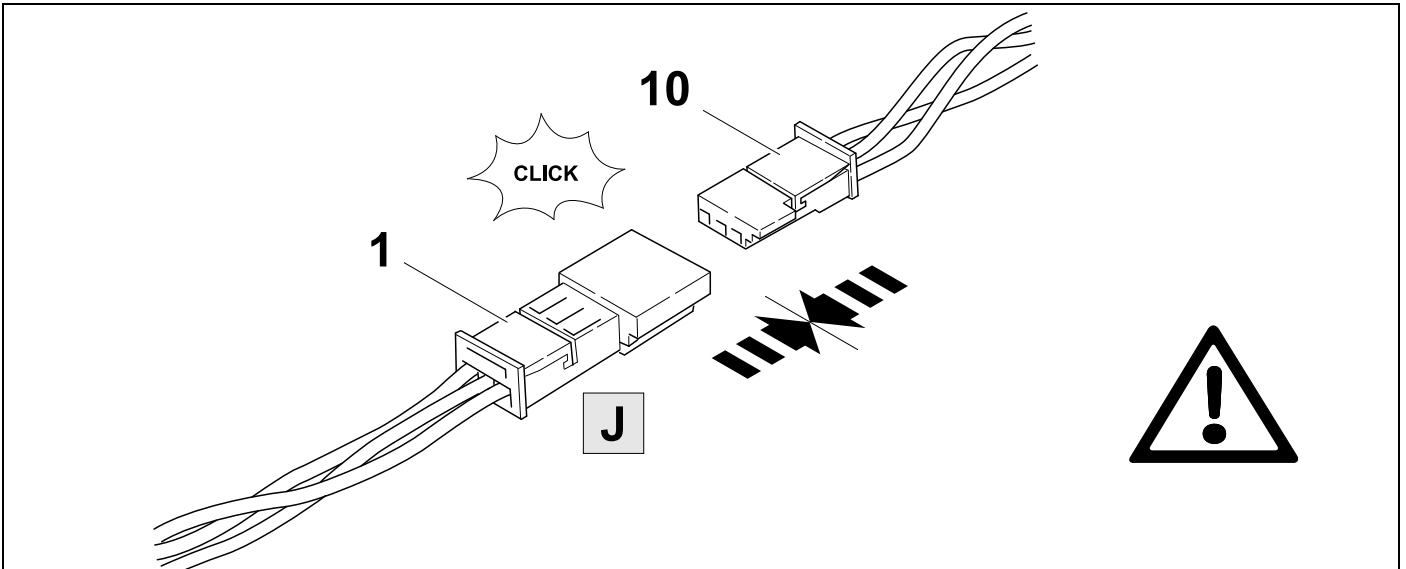

**24** **OPTION 1**

**OPTION 2**

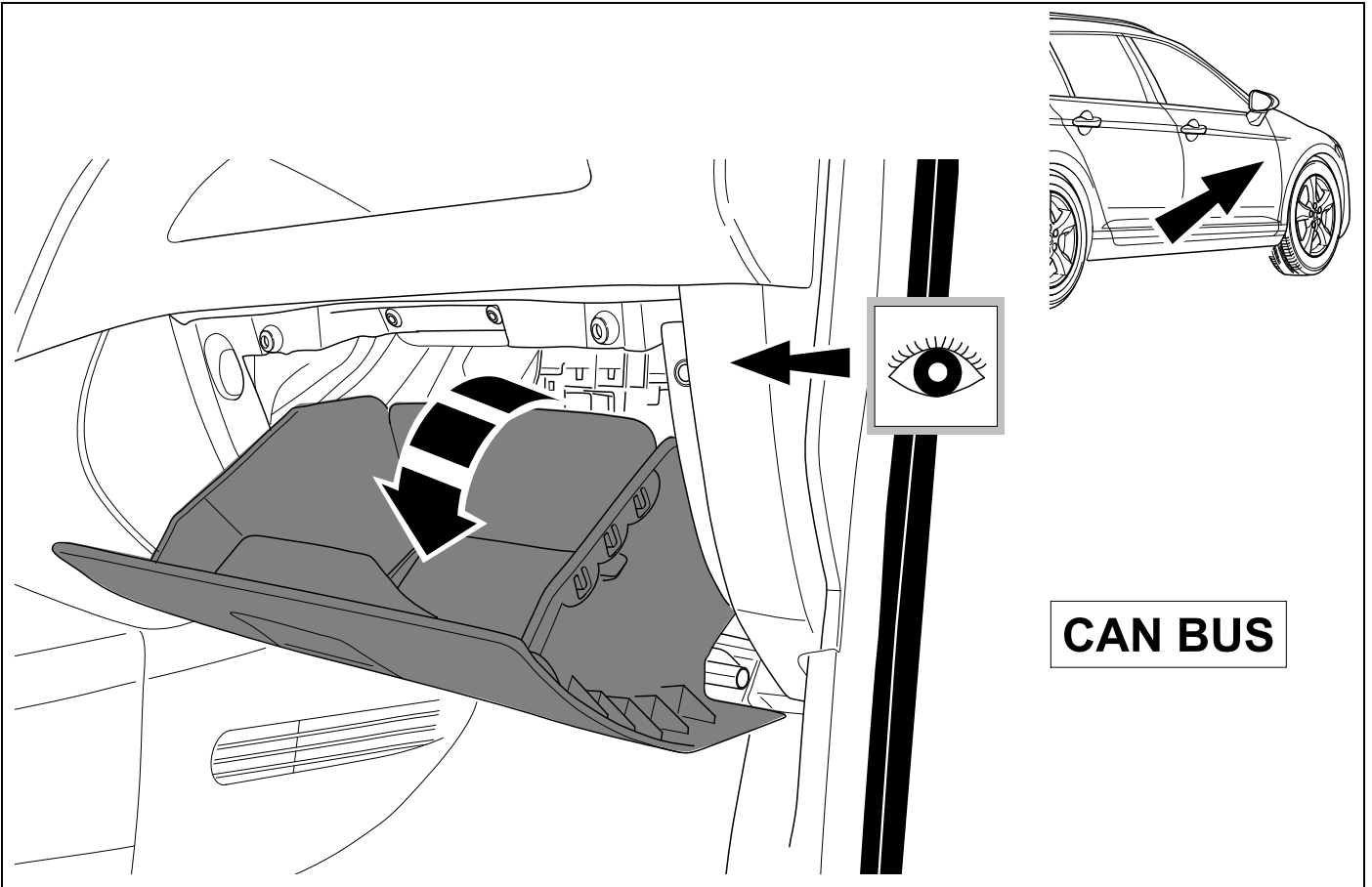

**25** **OPTION 1**



**9**

**OPTION 2**

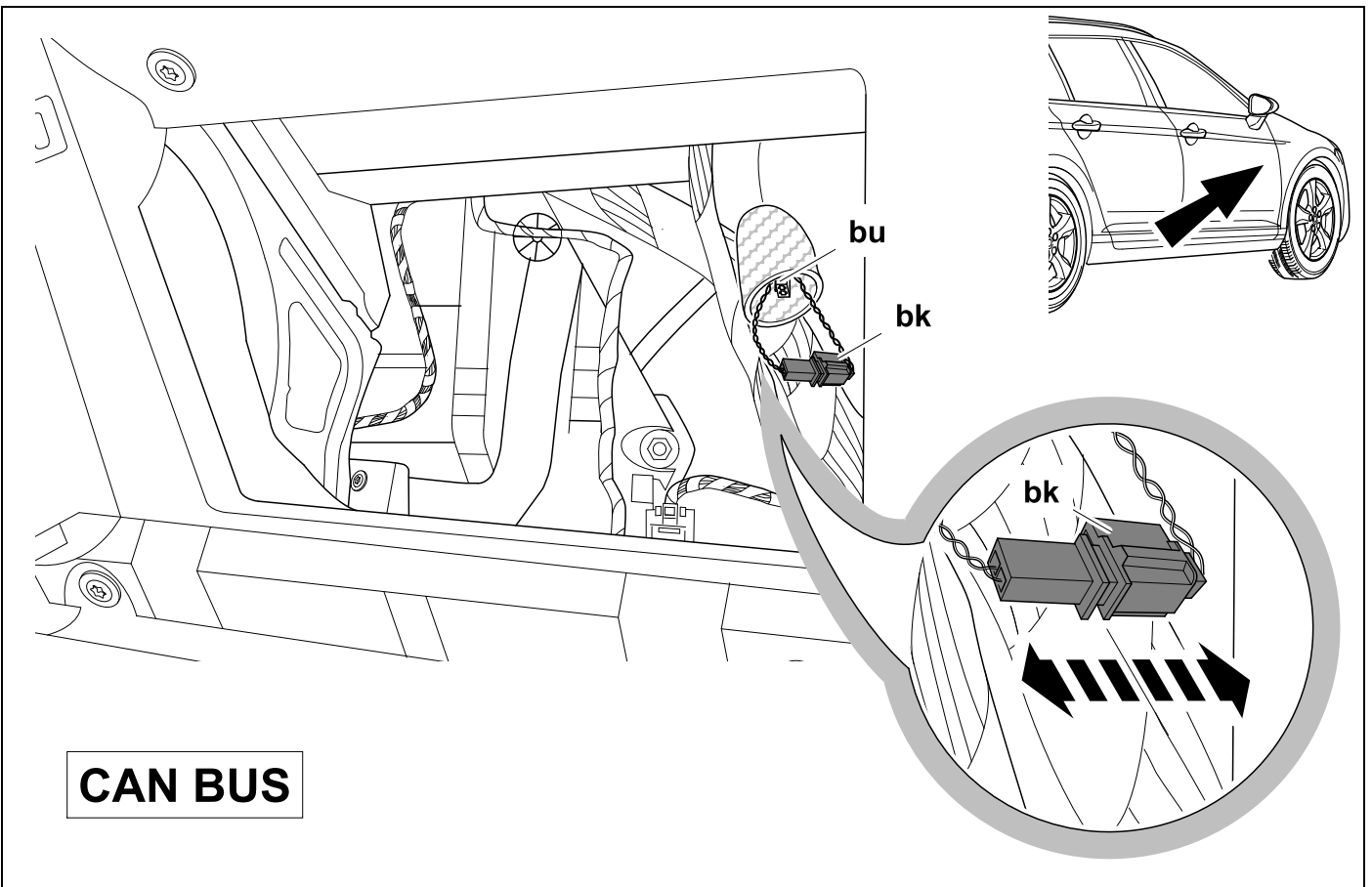

26 OPTION 1



9

OPTION 2

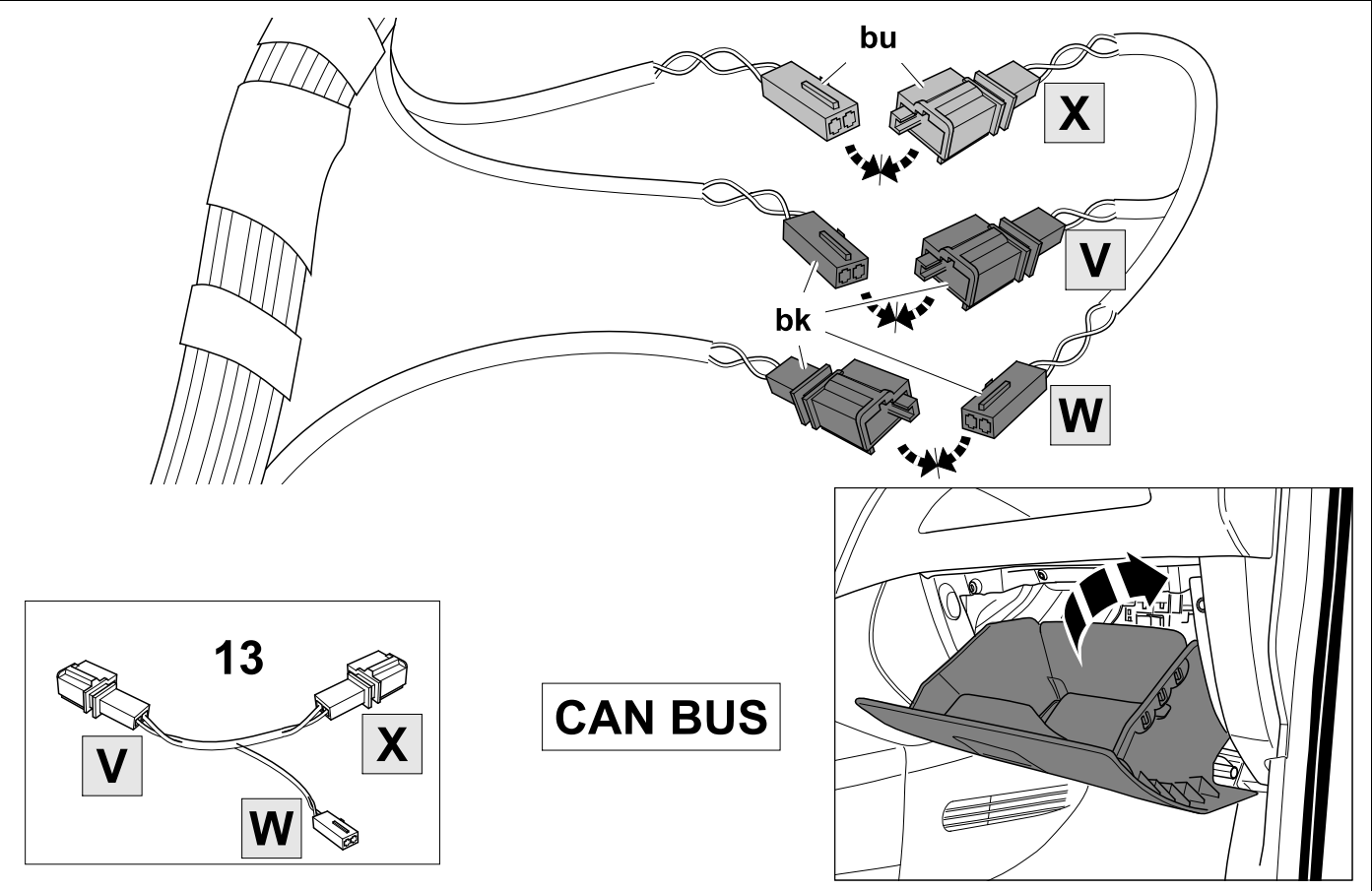

27



9

OPTION 3

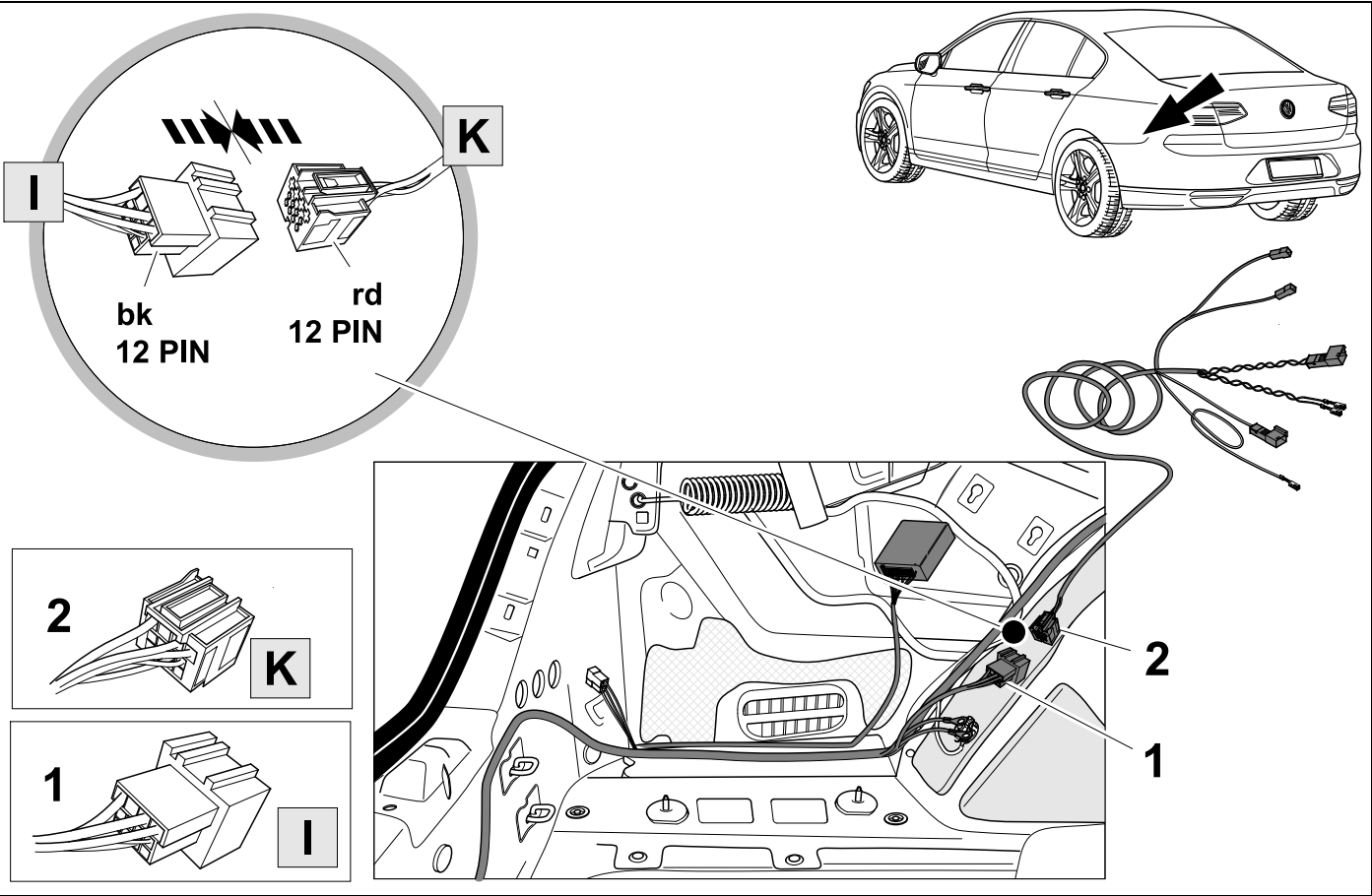

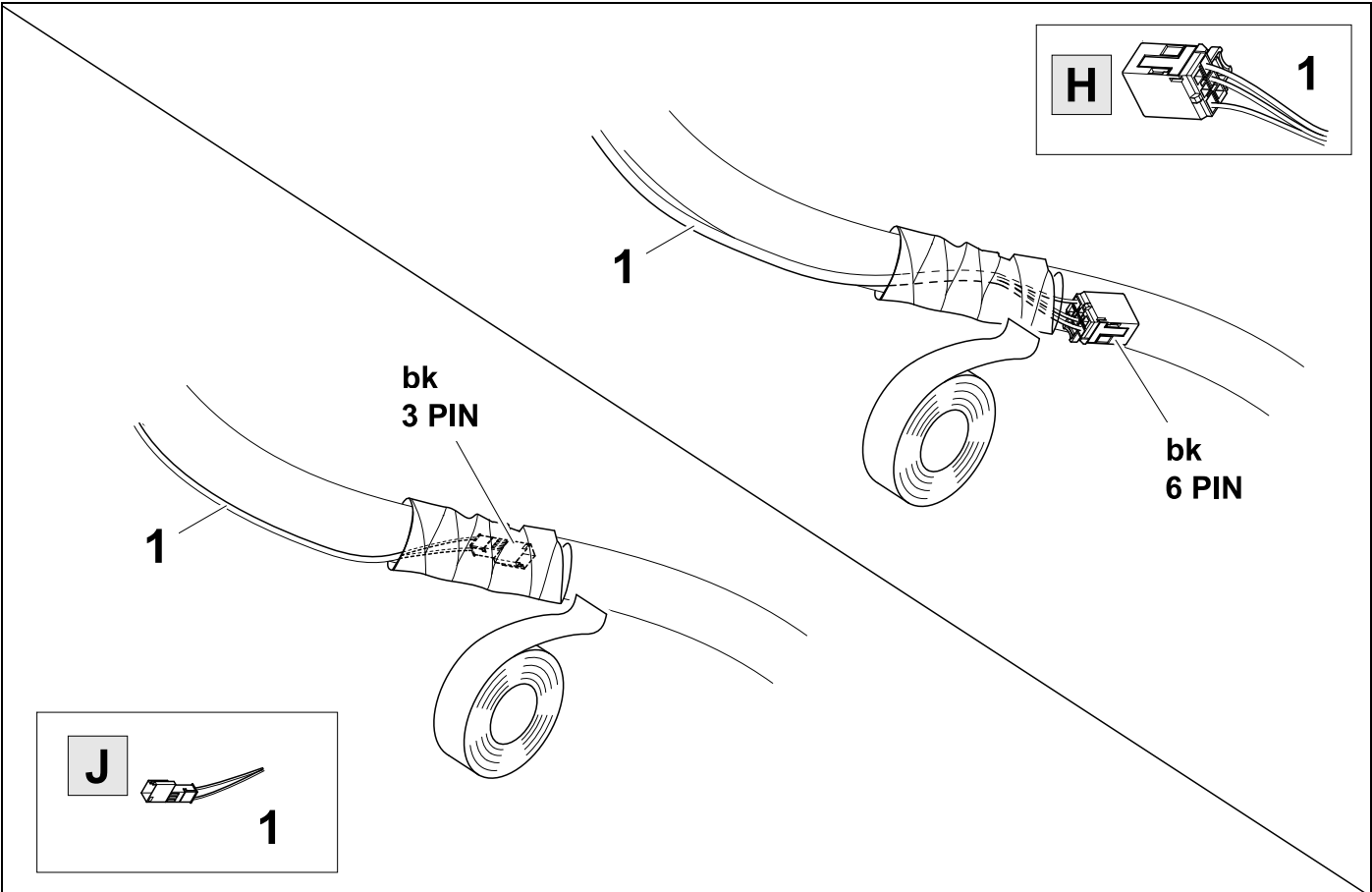

29 REMOVE

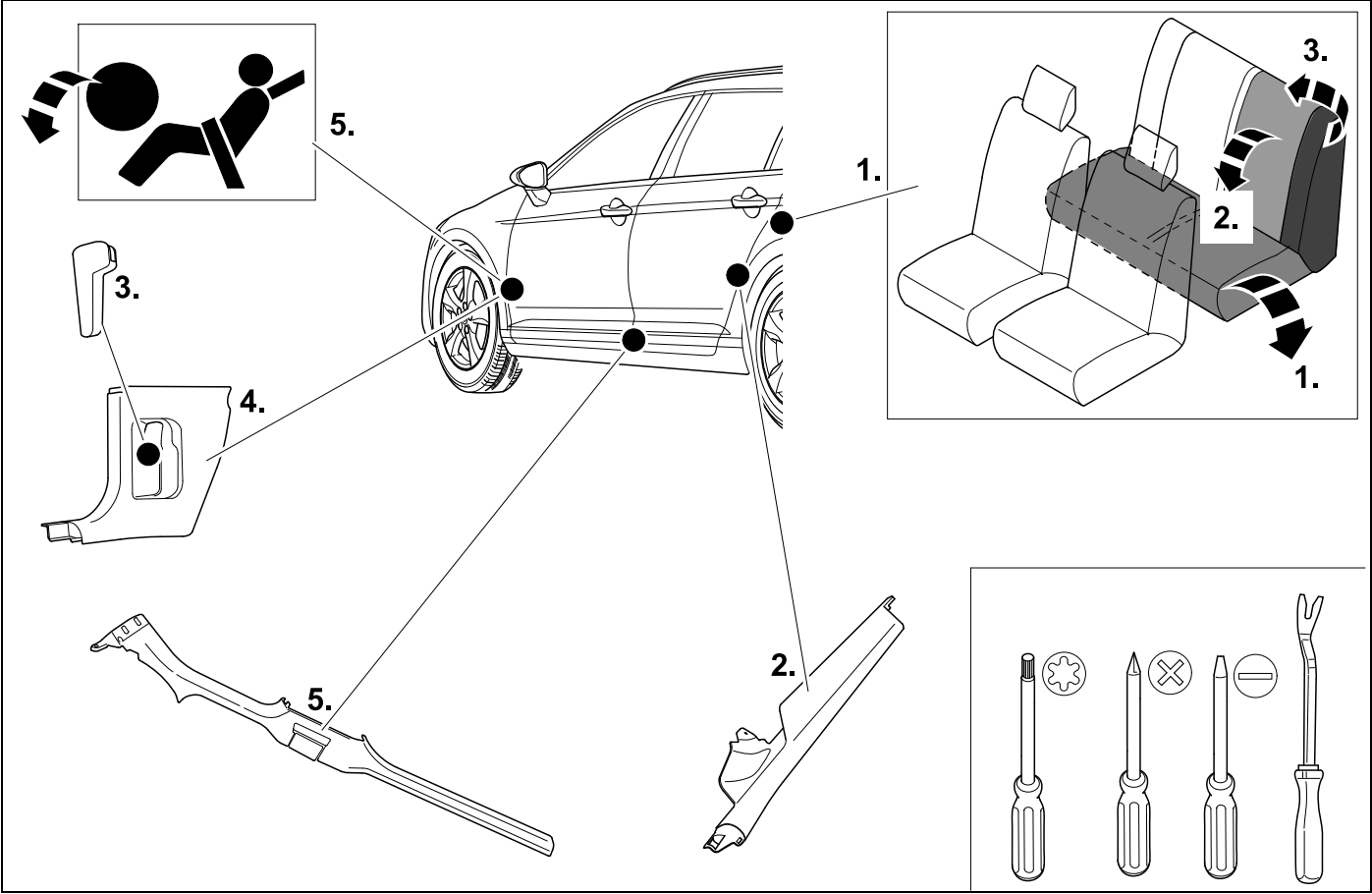

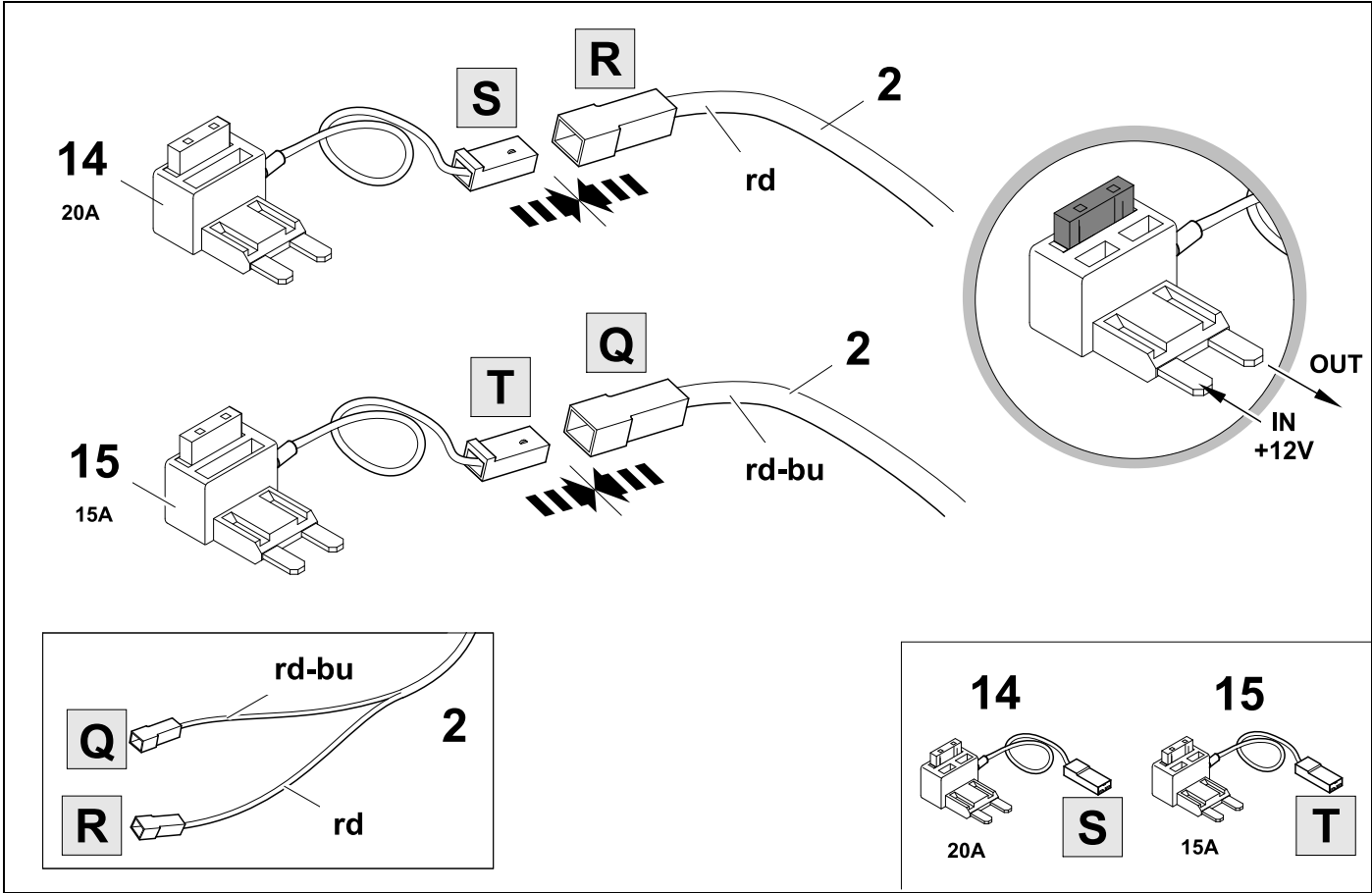
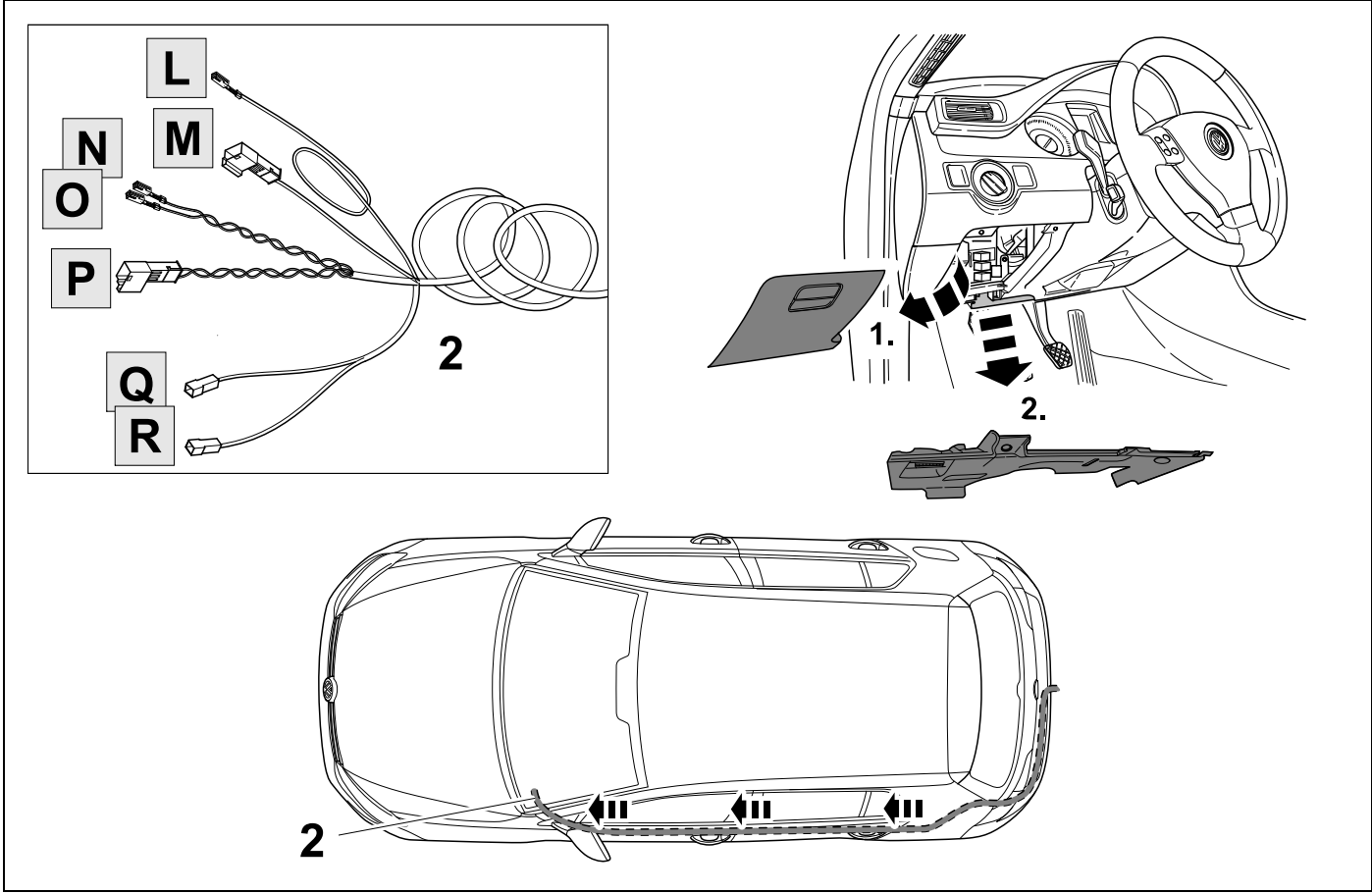

32



51

OPTION 3

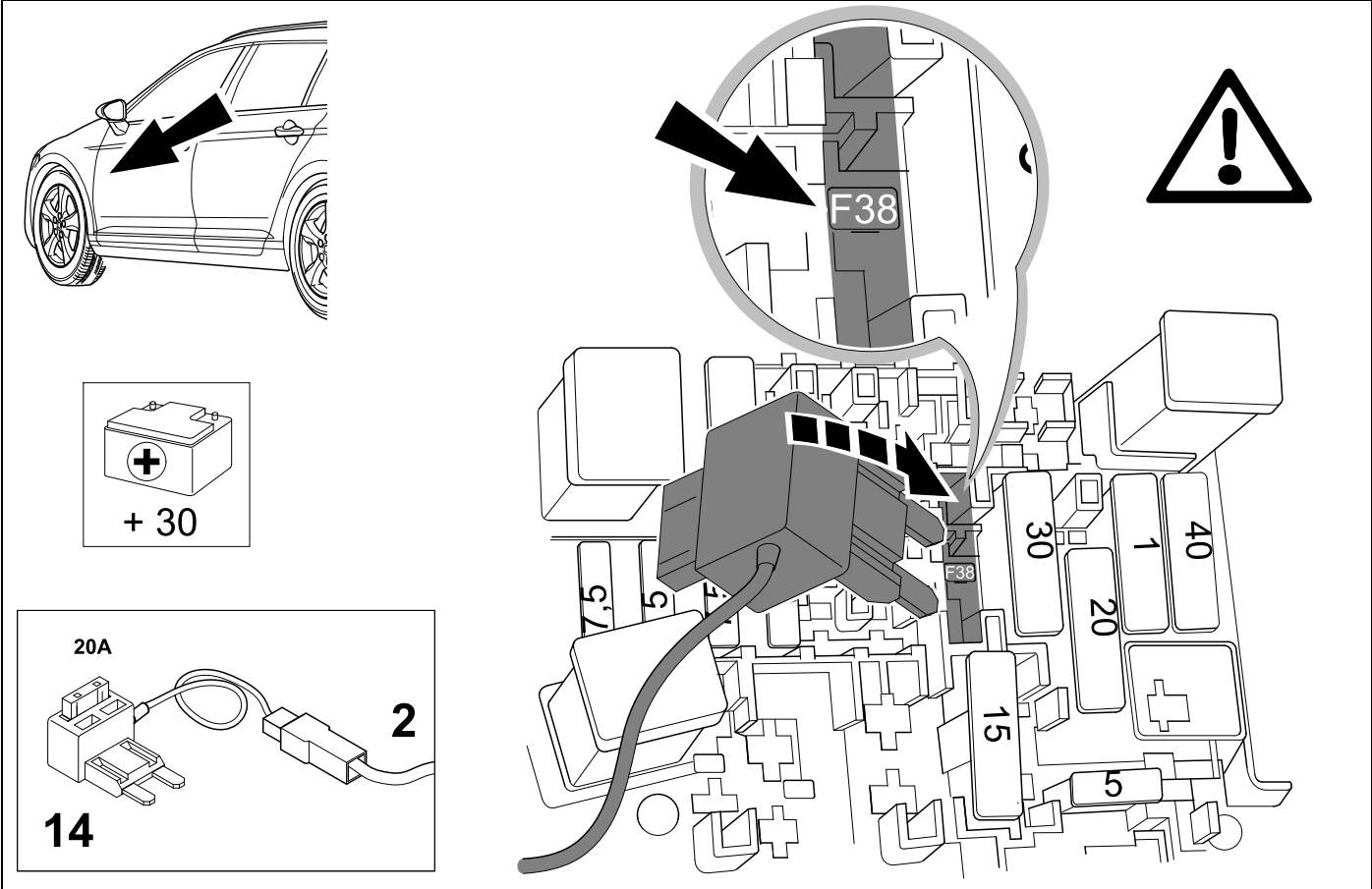

33



51

OPTION 3

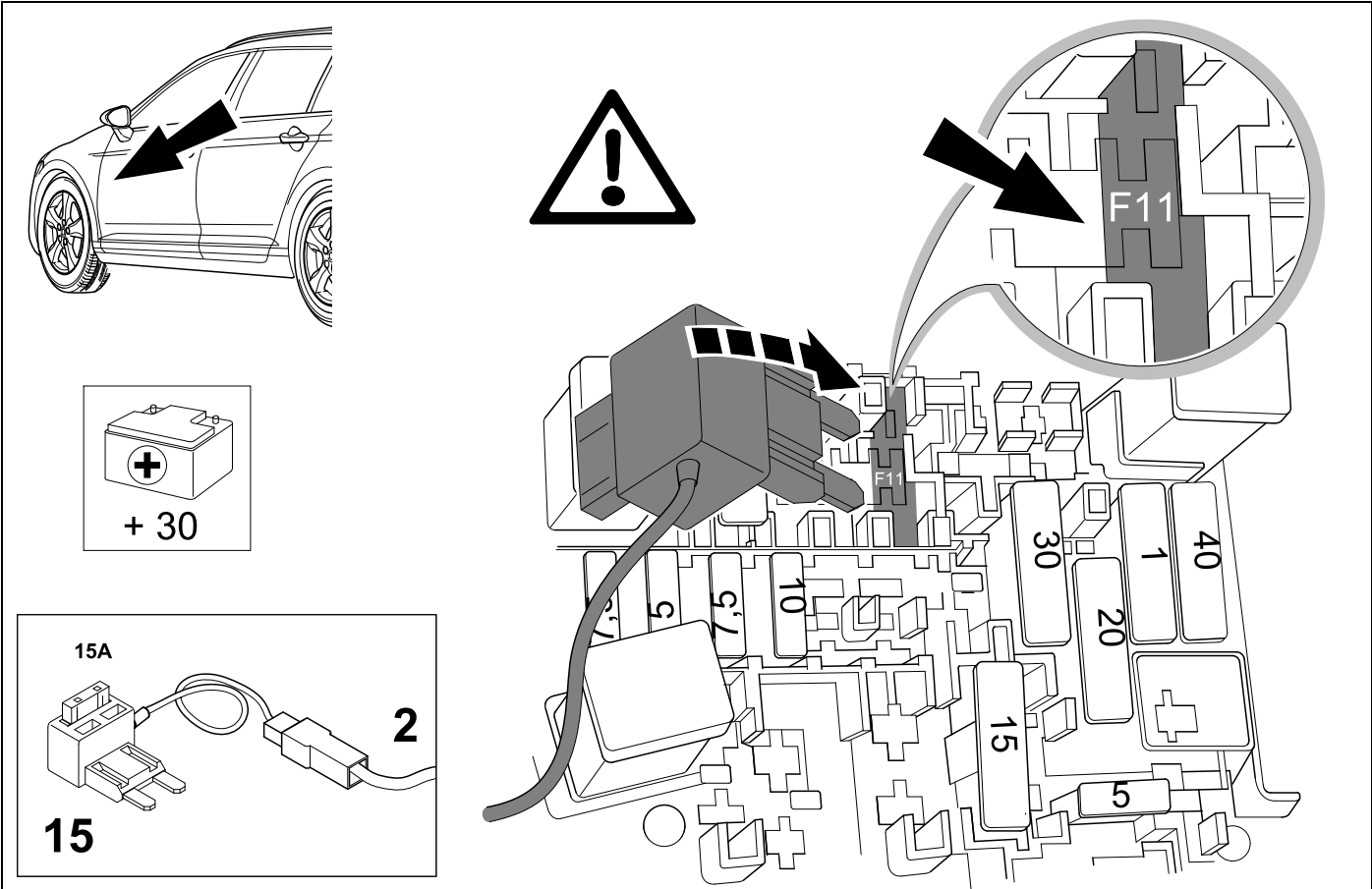

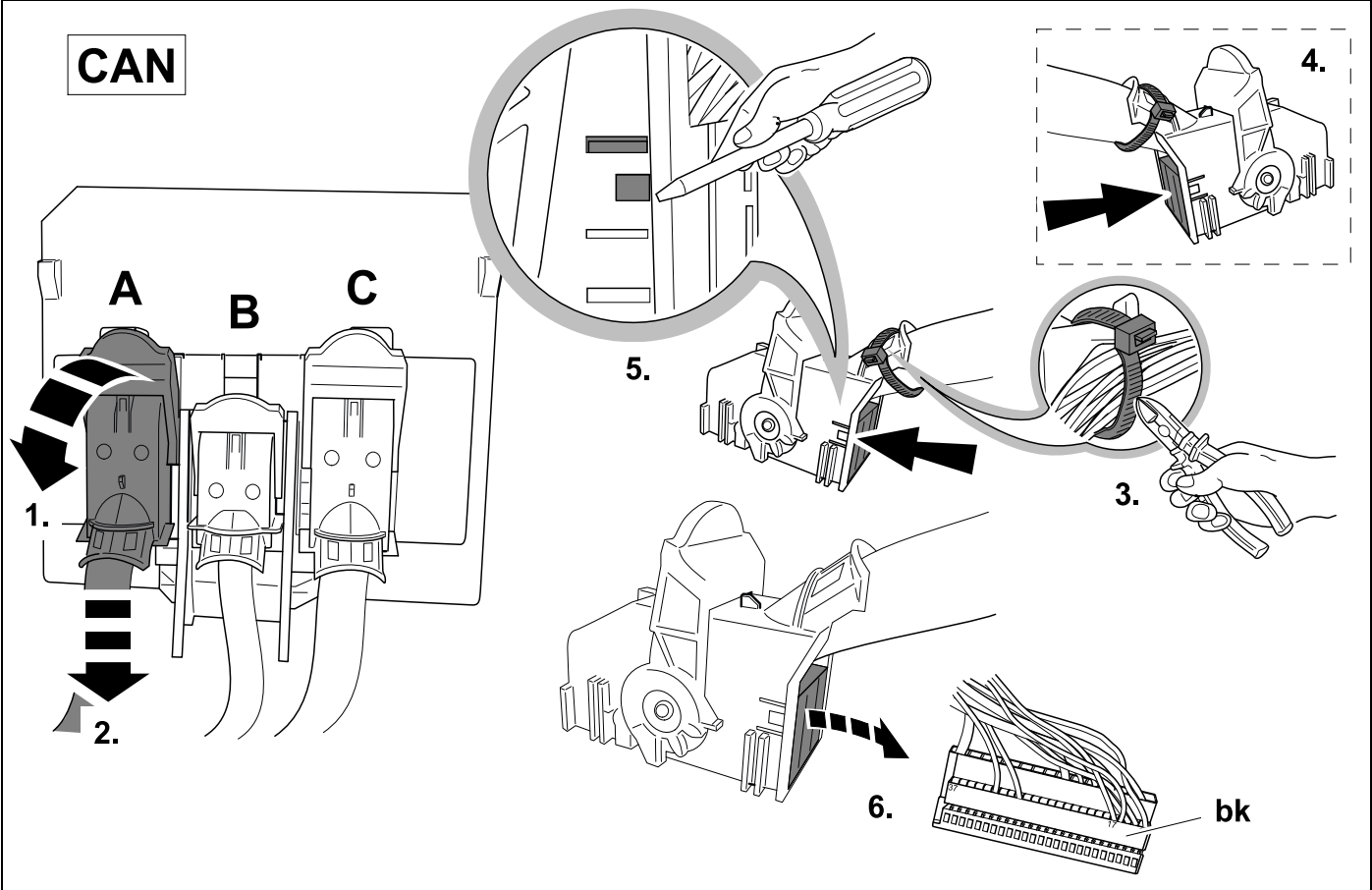
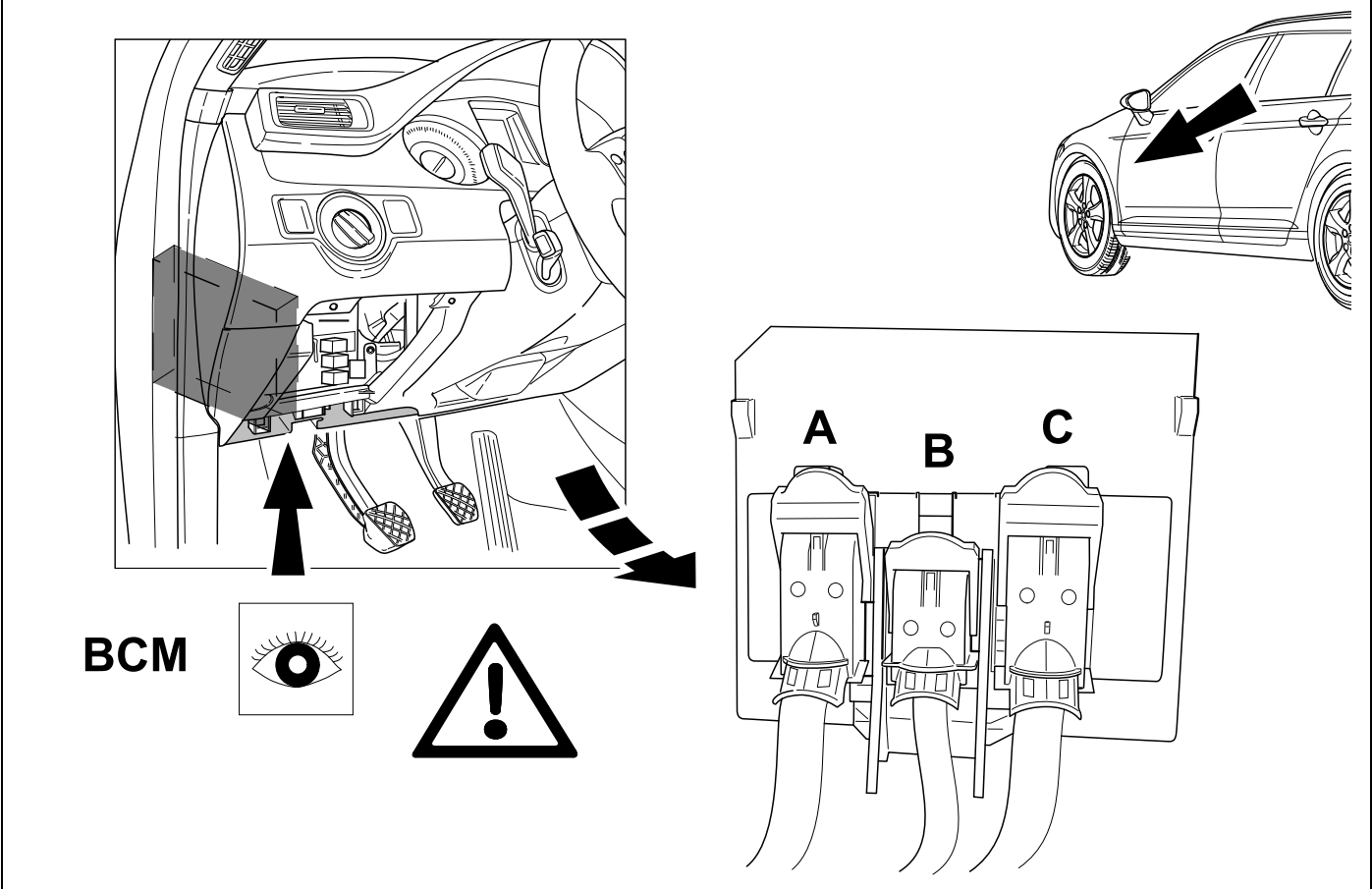



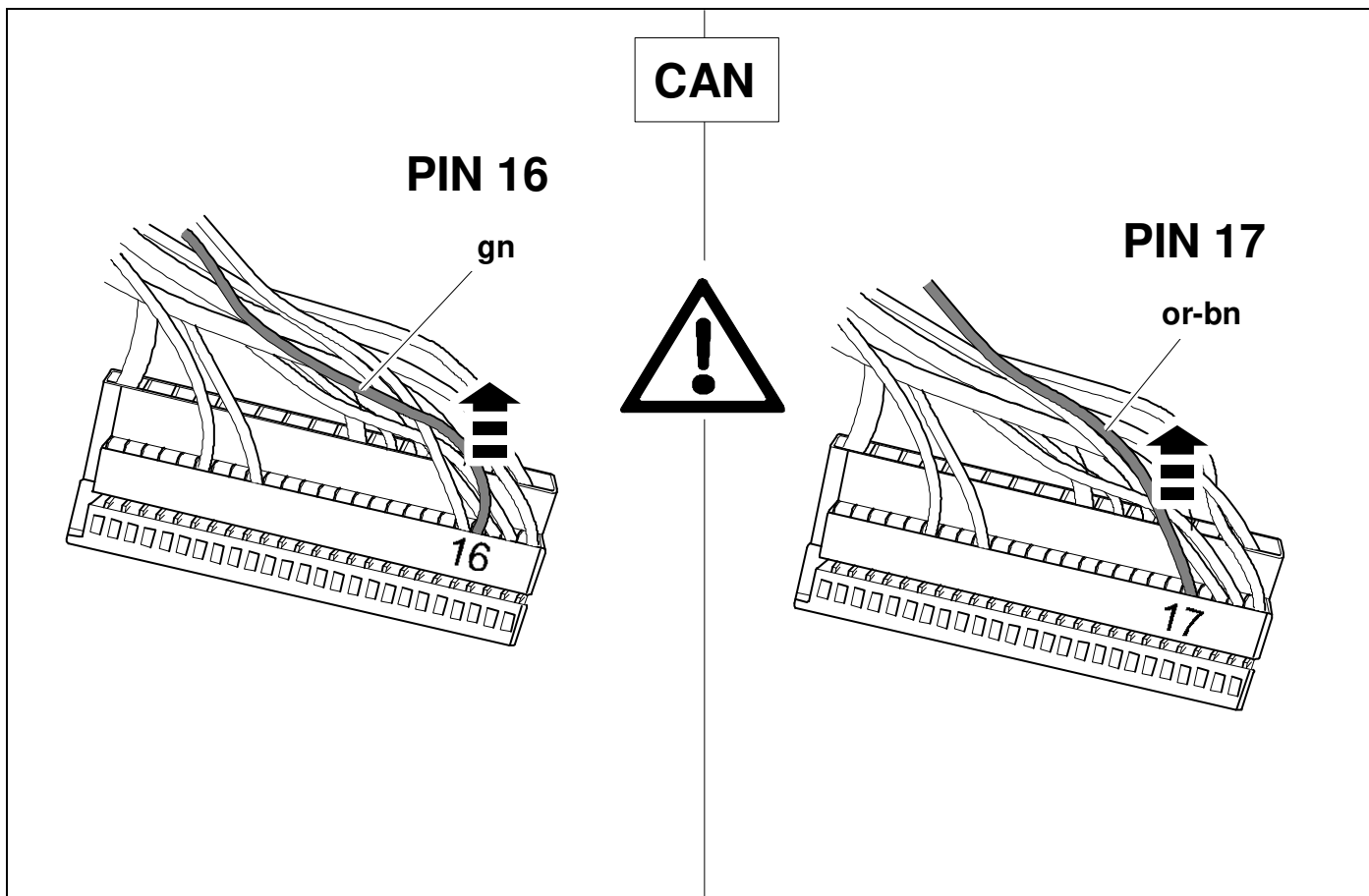
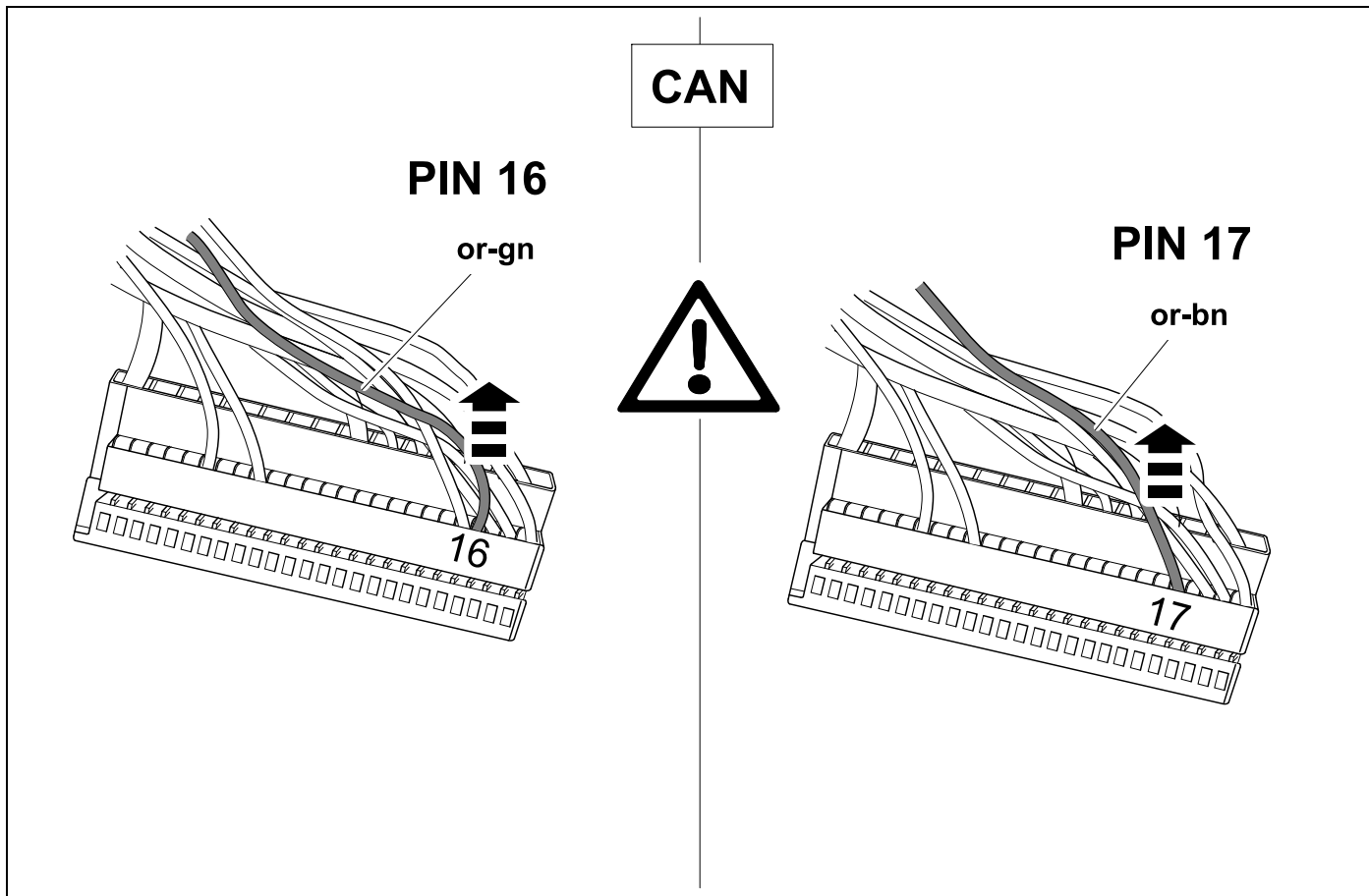

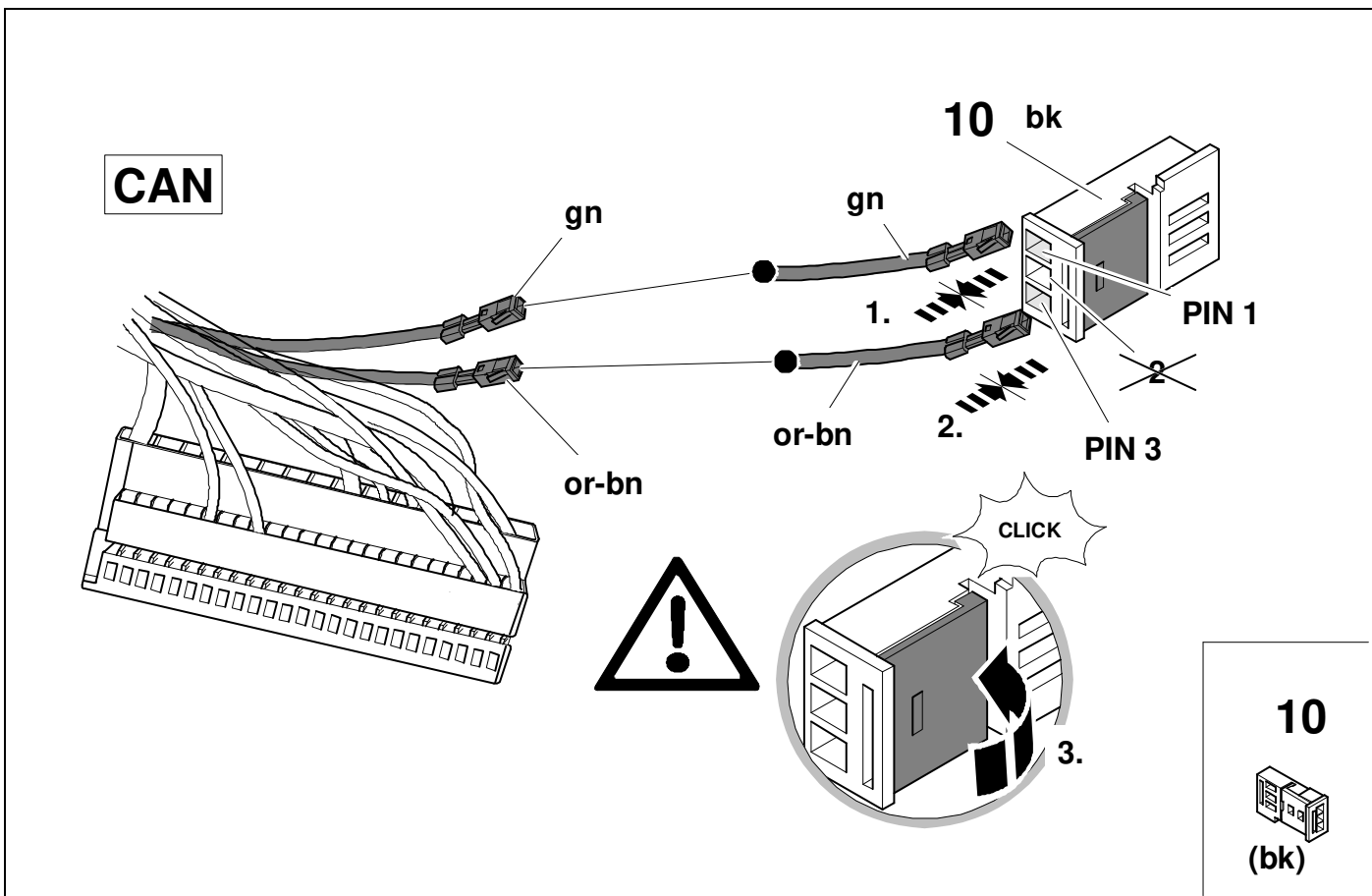
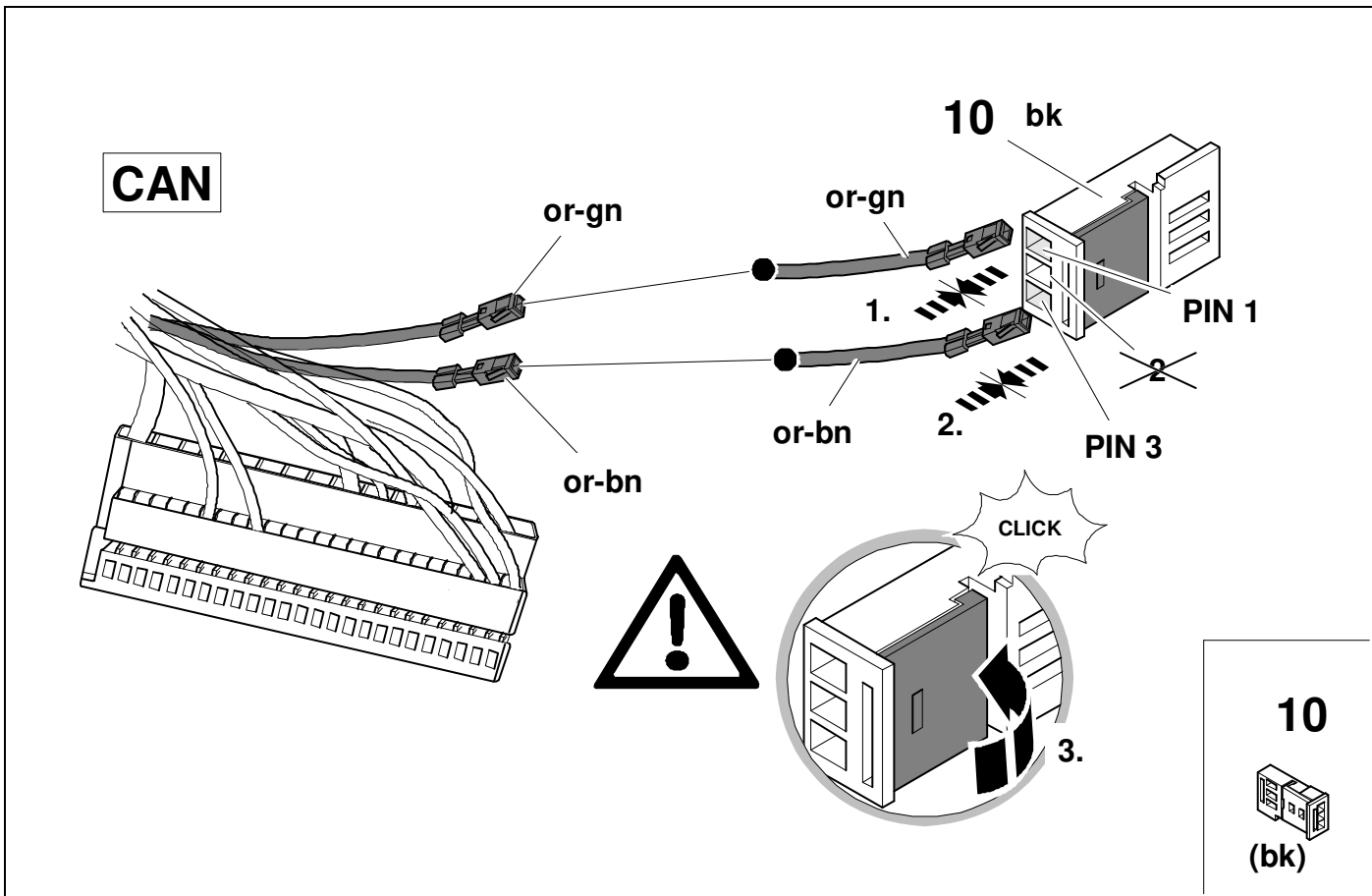

CAN

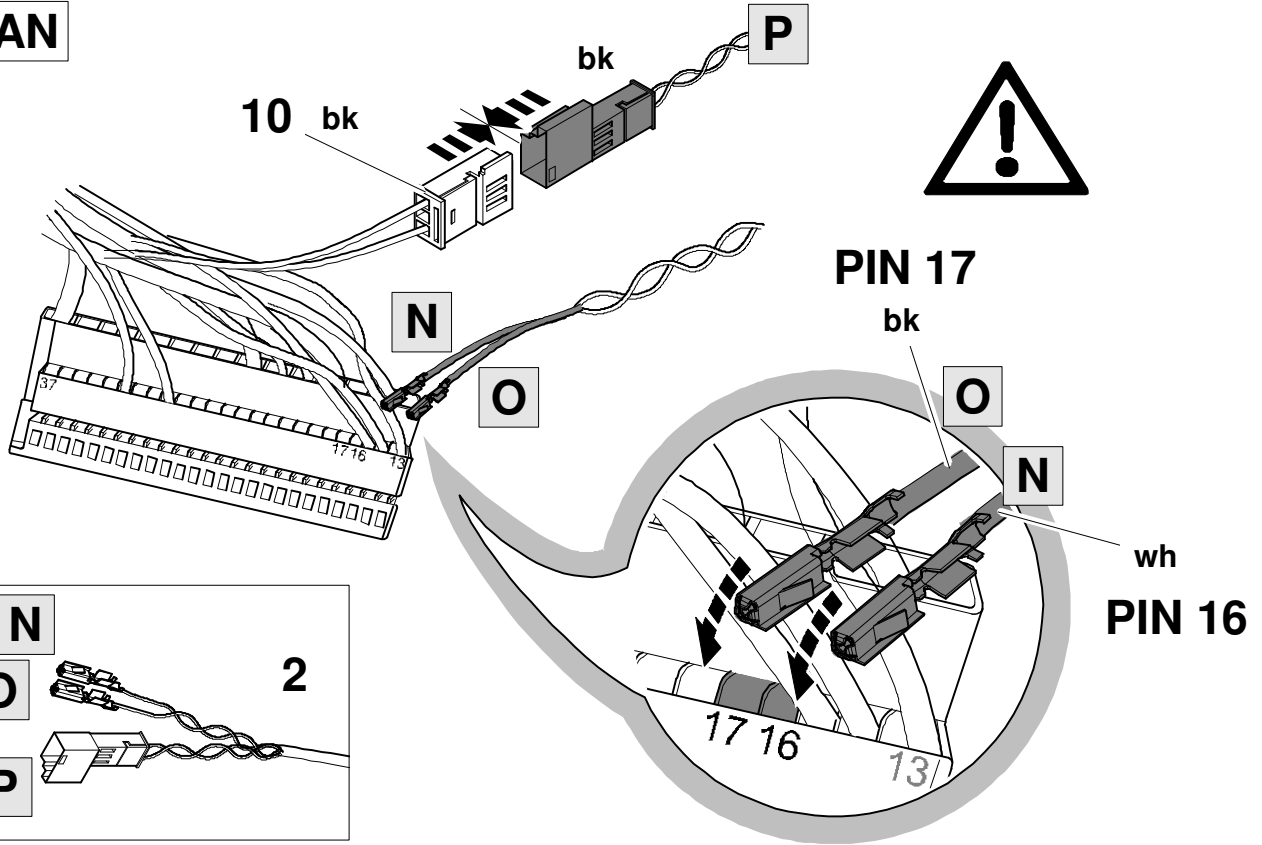

CAN

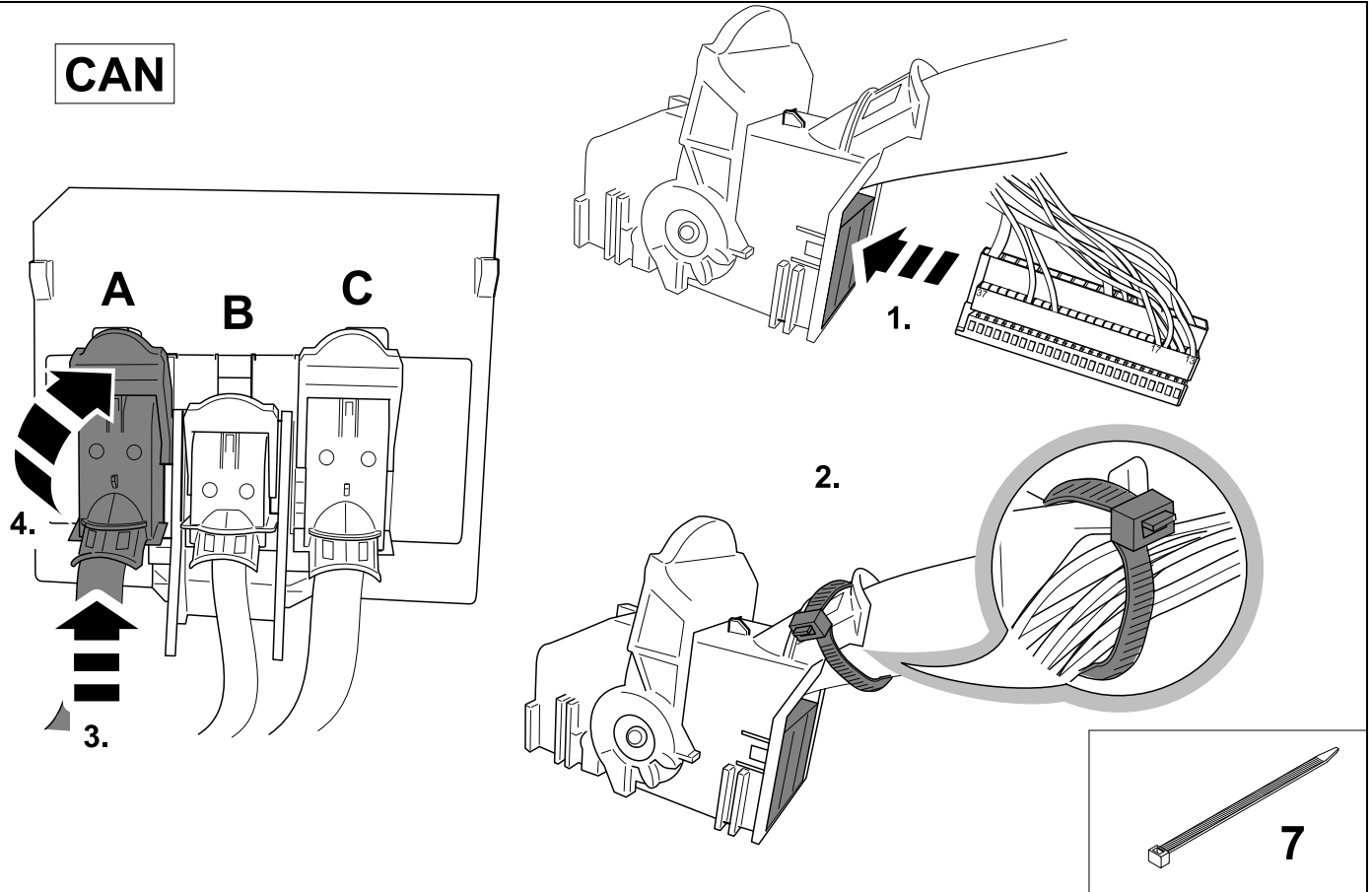

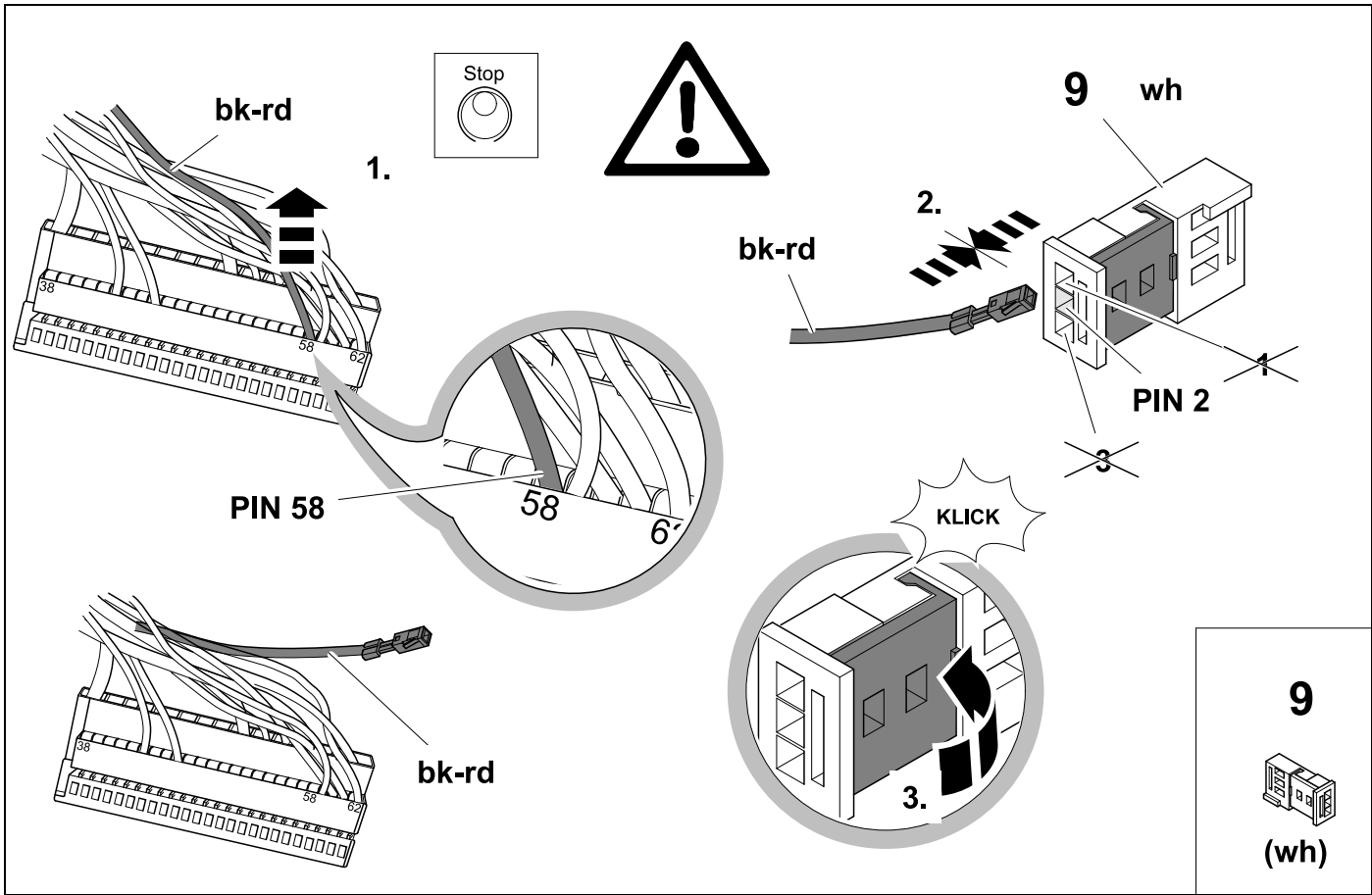
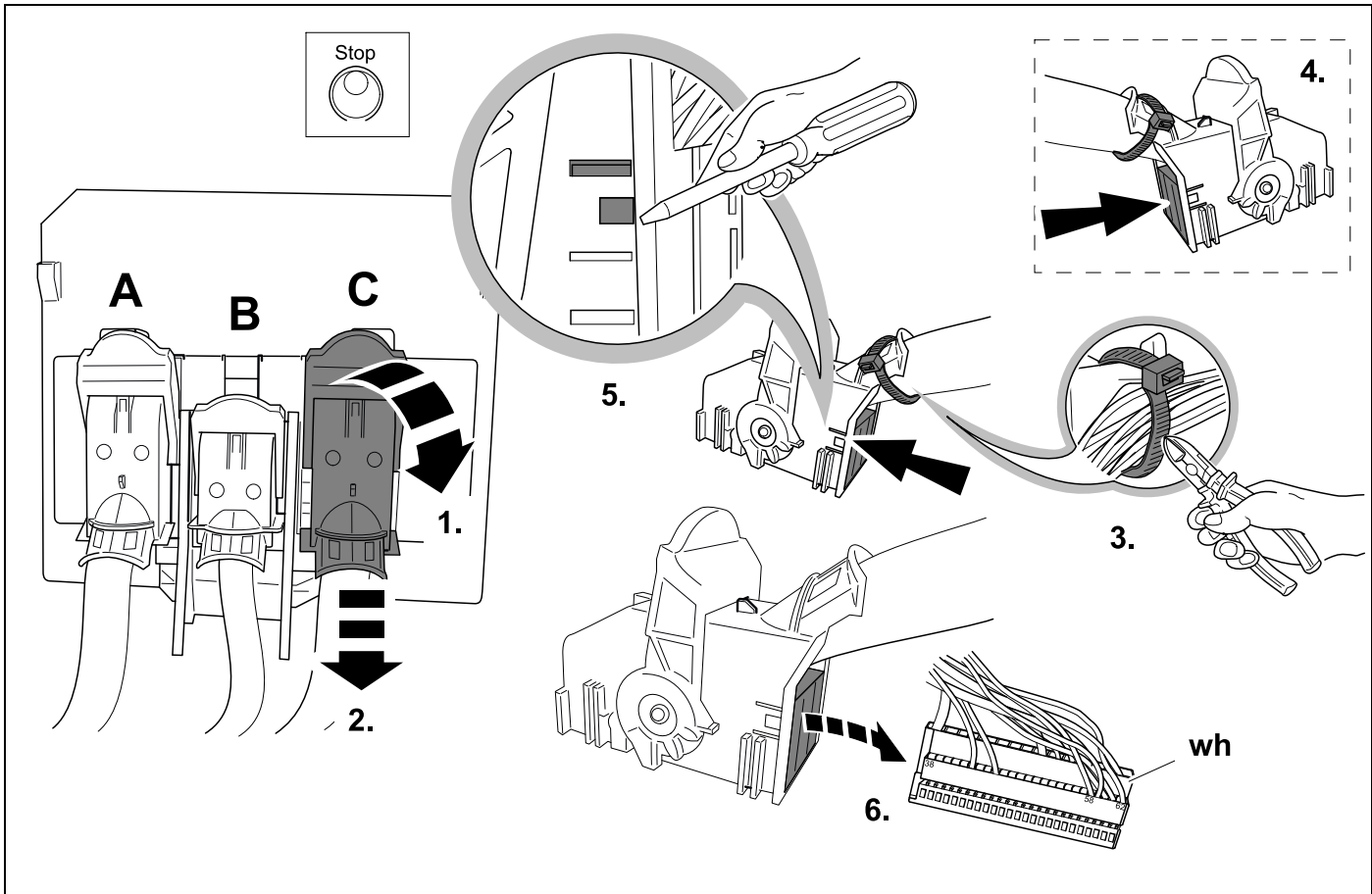

44



9

OPTION 3

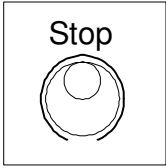
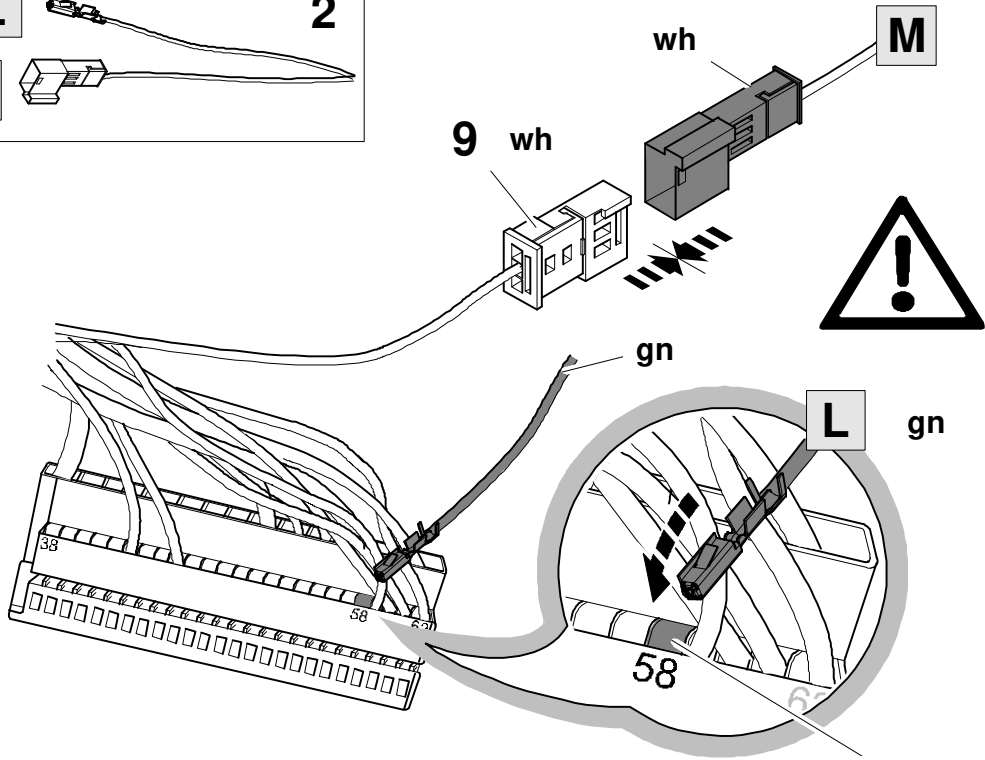
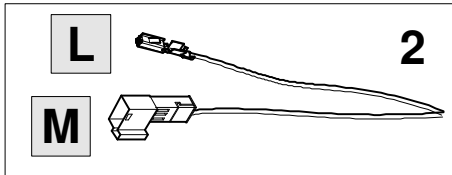

45

OPTION 3

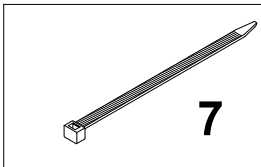
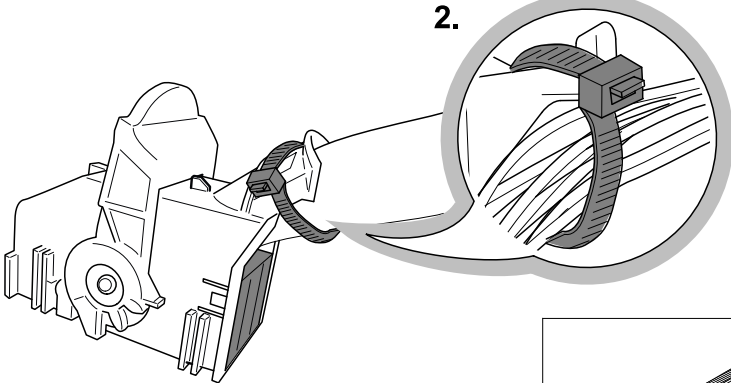
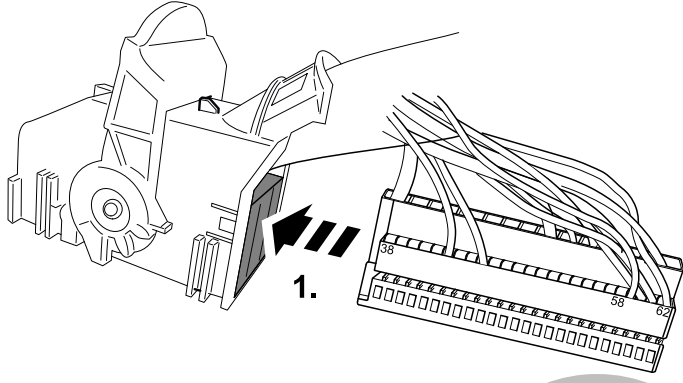
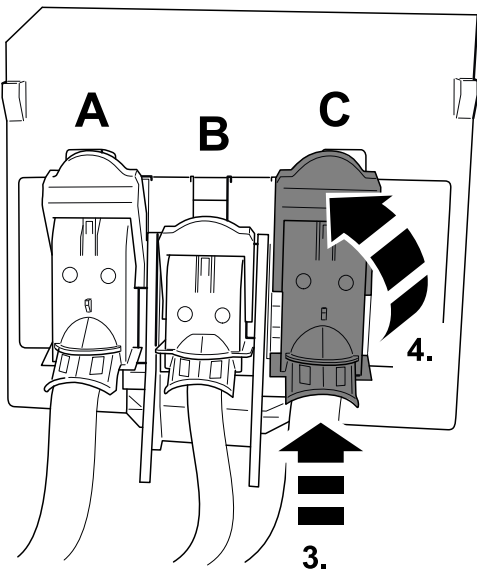
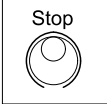

# 46 OPTIONAL

764159

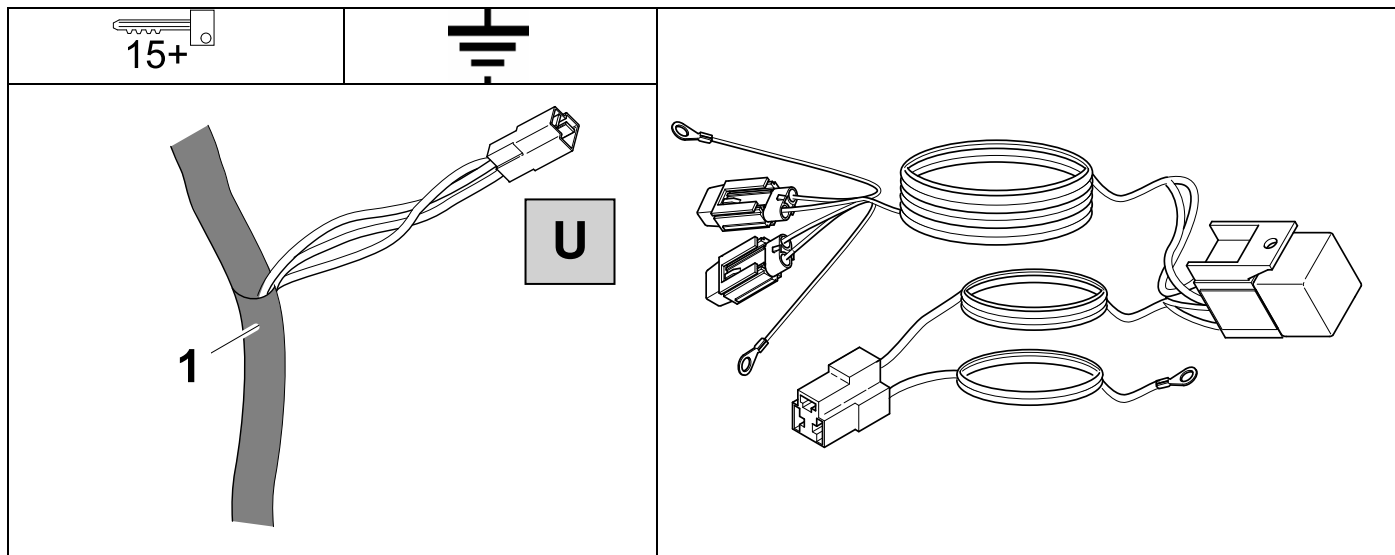

# 47

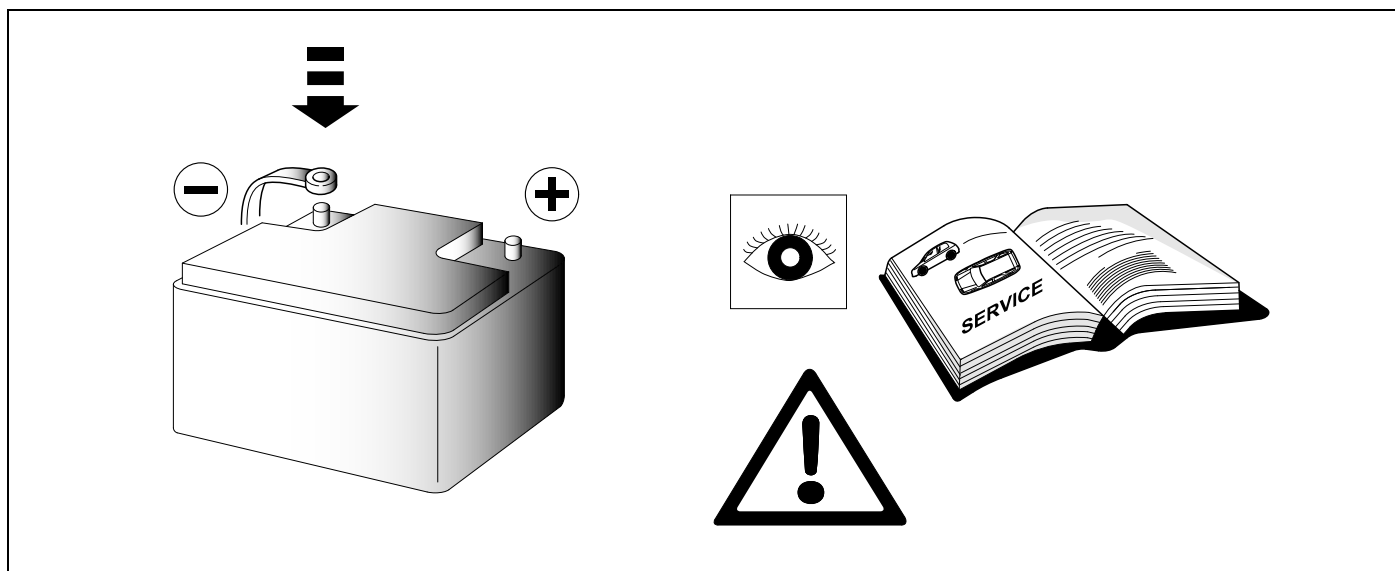

# 48 CHECK

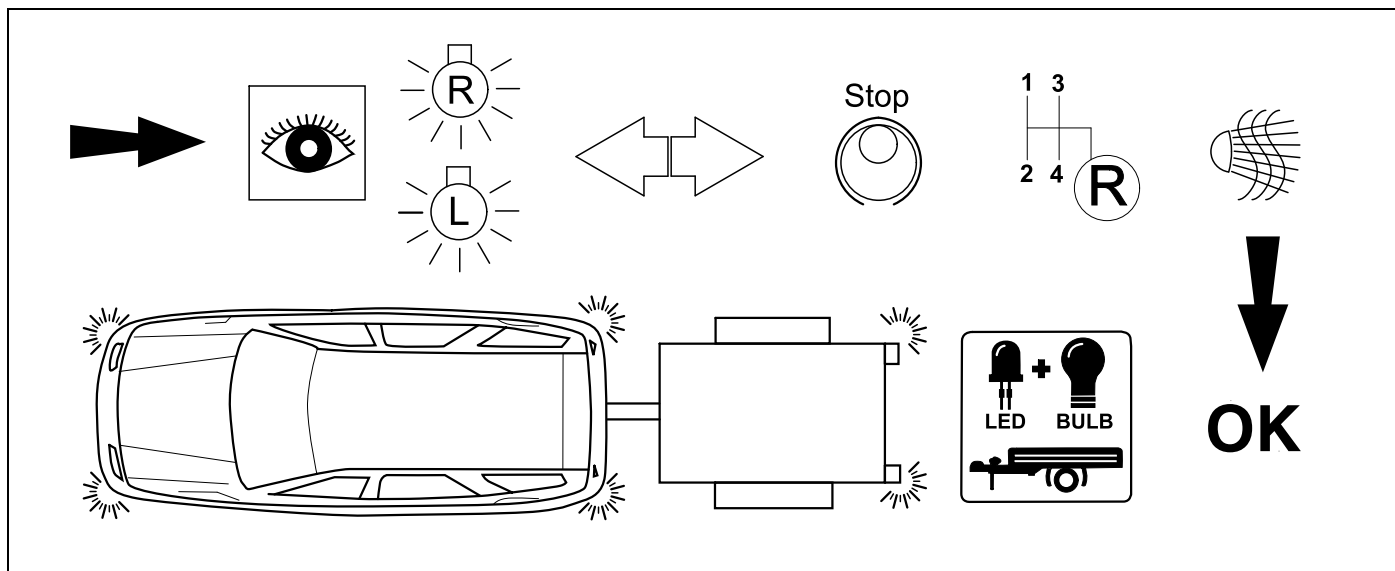

**49** OPTIONAL

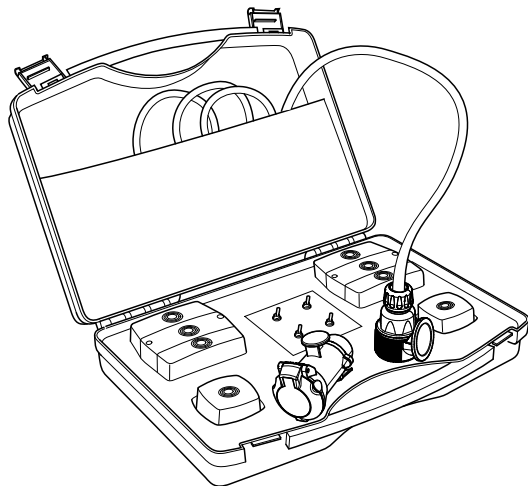

**Trailer Simulator  
for 7p and 13p  
sockets**

**765069**

**50** CHECK

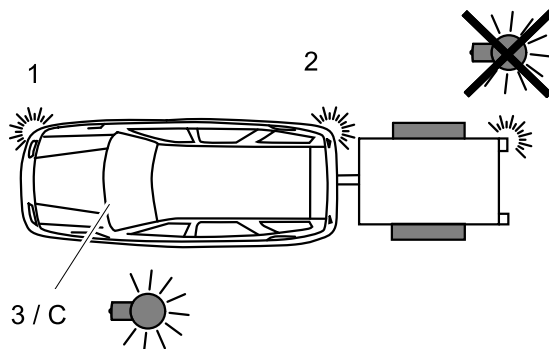
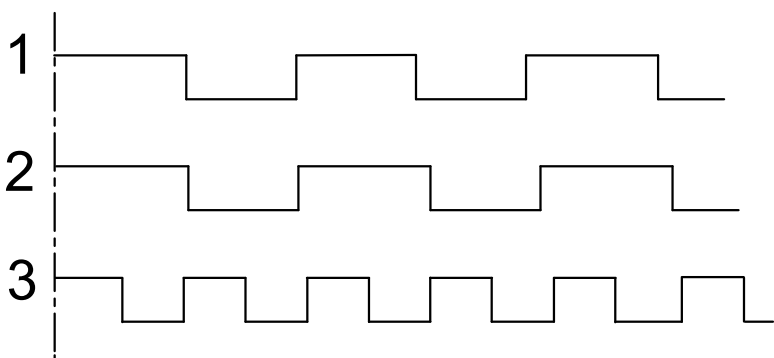

**51** Information Service



**32**

**+**

**33**

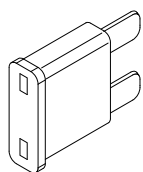

**20 A**

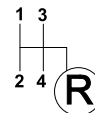
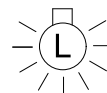
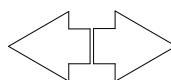
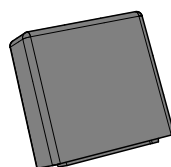
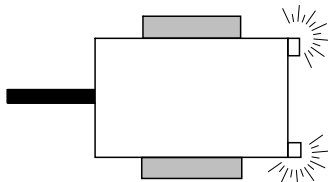

Stop

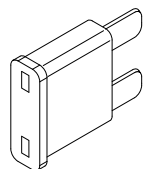
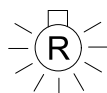

**15 A**

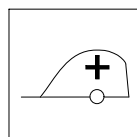
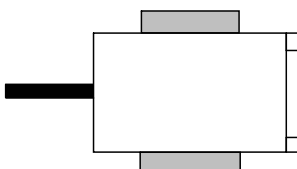

**Need help programming this wiringkit?**

If possible, we provide tips in our manuals on how the vehicle can be coded. It is always possible that more or different coding steps are required for your specific vehicle. That is why we recommend the use of Jifeline.

Jifeline codes your vehicle online with the most up to date knowledge.

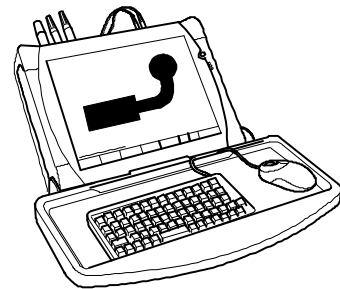
**IMPORTANT****UNBLOCK  
VEHICLE ECU  
BEFORE CODING**



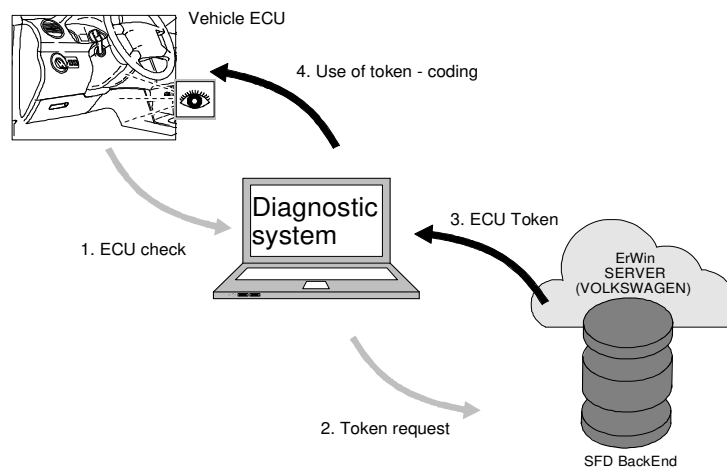

(GB)

1. It is a prerequisite that the user is registered in the SFD IT back end and in the Dealer Portal (in future, the Group Retail Portal).
2. The user would like to carry out SFD-protected services on one or more SFD-protected control units as part of a vehicle diagnosis.
3. The control unit reports that it is SFD-protected and asks for an activation token.
4. The vehicle diagnostic tester sends an activation request with the ID mark of the control unit and the desired scope to the SFD IT back end.
5. The SFD IT back end checks and authorizes the request and sends a signed activation token to the tester. The SFD IT back end logs the access (user ID, CU ID mark, time etc.).
6. The vehicle diagnostic tester sends the activation token to the control unit. The control unit checks the activation token and grants access to the relevant diagnostic object.

(D)

1. Vorbedingung: Der Nutzer ist im SFD-IT-Backend und im Händlerportal (zukünftig Group Retail Portal) registriert
2. Der Nutzer möchte im Rahmen einer Fahrzeugdiagnose an einem oder mehreren SFD-geschützten Steuergeräten SFD-geschützte Dienste ausführen.
3. Das Steuergerät meldet, dass es SFD-geschützt ist und fordert einen Freischalttoken.
4. Der Diagnosetester sendet eine Freischalt-Anfrage mit dem ID-Merkmal des Steuergeräts und dem gewünschten Umfang an das SFD-IT-Backend.
5. Das SFD-IT-Backend prüft und autorisiert die Anfrage und sendet einen signierten Freischalt-Token an den Tester. Das SFD-IT-Backend protokolliert den Zugriff (Nutzer-ID, SG-ID-Merkmal, Zeitpunkt etc.)
6. Der Diagnosetester sendet den Freischalttoken an das Steuergerät. Das Steuergerät überprüft den Freischalttoken und gewährt den Zugriff auf die entsprechenden Diagnoseobjekte.

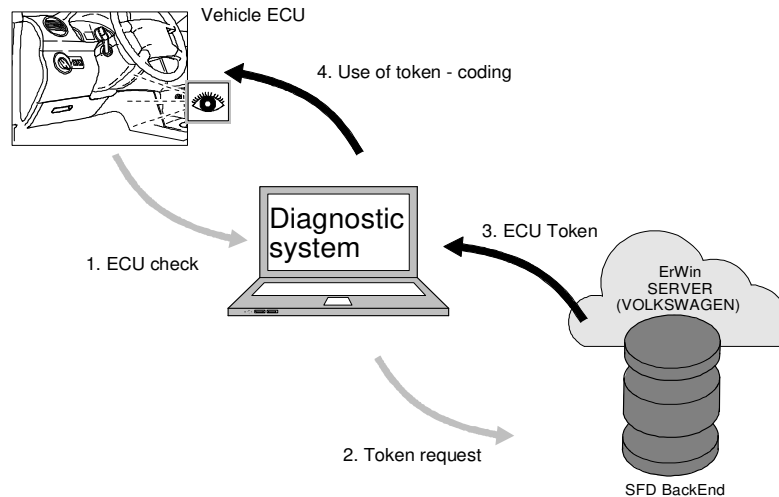

GB

1. A direct online token generation with the vehicle diagnostic tester does not work.
2. The workshop employee saves the activation request structure of the control unit that will be necessary for the generation of the token.
3. The user logs into the Dealer Portal (in future, the Group Retail Portal) using a different computer and accesses the token generation website of the SFD back end via the SFD application.
4. The user enters the activation request structure of the control unit, generates an activation token with it, and copies this over to the vehicle diagnostic tester (e.g. using a USB stick).
5. The user executes a function on the tester in order to send the activation token manually to the control unit.
6. The control unit checks the activation token and grants access to the relevant diagnostic object.

D

1. Ein direkter Online-Tokenabruf mit dem Diagnose-Tester funktioniert nicht.
2. Der Werkstattmitarbeiter speichert die Freischalt-Anfragestruktur des Steuergeräts, die für die Generierung des Tokens benötigt wird.
3. Er meldet sich mit einem anderen Rechner im Händlerportal (zukünftig Group Retail Portal) an und gelangt über die SFD-Applikation auf die Tokenabruf- Webseite des SFD-Backends.
4. Er gibt die Freischalt-Anfragestruktur des Steuergeräts ein, ruft damit einen Freischalttoken ab und kopiert diesen auf den Diagnose-Tester (z. B. per USB-Stick).
5. Der Nutzer führt eine Funktion auf dem Tester aus, um den Freischalttoken manuell an das Steuergerät zu senden.
6. Das Steuergerät überprüft den Freischalttoken und gewährt den Zugriff auf die entsprechenden Diagnoseobjekte

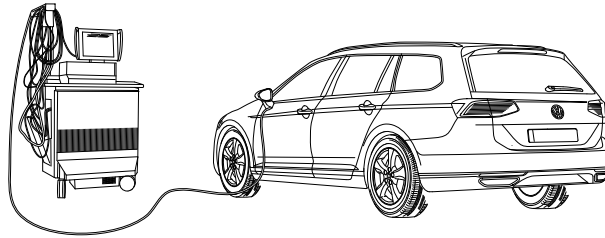

D

GB

**Codierung mit VCDS, bitte beachten:**

Der nachfolgend beschriebene Ablauf zur Codierung bzw. Freischaltung auf Anhängerbetrieb dient lediglich zur allgemeinen Orientierung und kann je nach Modell (Motorisierung / Ausstattung) stark variieren. Gegebenenfalls müssen weniger oder noch weitere Steuergeräte angepasst werden.

- **Nach dem Verbinden mit VCDS muss in der\_19 (Verbauliste) das Steuergerät „69 Anhängerfunktion“ auf > codiert gesetzt werden**
- **Codierung EZE\_09 (Elektronisches Zentralelektrik-Steuergerät; möglicher Login 31347)**  
Diagnose / Eigendiagnose / Vernetzungsplan  
Eigendiagnose Steuergerät  
Codieren; hitch\_ecu > installed;  
Bei Modellen (MJ 2017 >>) Anpassung > Kanal -Vernetzung Anhängeranschlussgerät > verbaut
- **Codierung ZKS\_46 (Zentralmodul / Komfortsystem)**  
trailer monitoring > auf aktiv setzen  
trailer control unit > verbaut
- **Codierung\_03 (Bremsenelektronik; Login 61378)**  
Anpassung > Kanal - Gespannstabilisierung,  
Wert auf > aktiviert setzen
- **Codierung SWA\_3C (Spurwechselassistent)**  
ECU for draw bar > with ECU for draw bar
- **Codierung SCH\_17 (Schalttafeleinsatz)**  
Trailer > ja
- **Codierung RFK\_6C (Rückfahrkamerasystem)**  
equipment\_ahk > verbaut
- **Codierung STF\_74 (Fahrwerkssteuerung)**  
Anhänger > verbaut
- **Codierung EPH\_76 (Einparkhilfe Steuergerät)**  
Anhänger > Anhängervorrichtung manuell abnehmbar
- **Codierung DiS\_13 (Distanzregelung Steuergerät, möglicher Login 20103);**  
Control module for towing sens > verbaut oder  
Control module for trailer recognition > verbaut  
(Byte 03 Bit 03)
- **Codierung FFF\_A5 (Frontsensorik Steuergerät)**  
AAG > coded
- **Codierung HDE\_6D (Heckdeckelelektronik Steuergerät)**  
Anhänger > verbaut

**Wichtiger Hinweis zu Codierung bzw. Freischaltung auf Anhängerbetrieb**

Die vorab genannten Einstellungen werden im Bordnetz des Fahrzeuges vorgenommen und lokal abgespeichert. Bei generellen Updates der Fahrzeugsoftware (beispielsweise im Rahmen von Service- oder Instandsetzungsarbeiten) können diese Einstellungen unter Umständen wieder überschrieben und gelöscht werden. In diesem Fall muss die Freischaltung auf Anhängerbetrieb nach dem Update noch einmal lokal aktualisiert werden. Diagnosehinweise in Bezug auf Anhängerbetrieb, die bei Soll-/Ist- Vergleichen mit den im Herstellerwerk hinterlegten Daten auftreten können, liegen ggf. der lokalen Freischaltung zu Grunde.

**Coding with VCDS, please note:**

The procedure described below for encoding and enabling the trailer mode only serves for a general orientation and can vary greatly depending on the model (motorisation / equipment). If necessary less or further control units will have to be adapted.

- **After connecting to VCDS, the "69 trailer function" controller has to be set to encoded in the \_19 installation list.**
- **Coding EZE\_09 (electronic central electric controller; Login 31347)**  
Diagnosis / Networking plan / Controller self-diagnosis  
encode hitch\_ecu > installed  
Vehicles from (MJ 2017>>) adjustment > channel -integration trailer control unit > installed
- **Coding ZKS\_46 (Central module convenience system)**  
trailer monitoring > put on active trailer control unit > installed
- **Coding\_03 (Brake Electronics; Login 61378)**  
Adjustment > channel - trailer stabilization,  
change value to > active
- **Encoding SWA\_3C (Lane Change Assist)**  
ECU for draw bar > with ECU for draw bar
- **Encoding SCH\_17 (Dash panel insert)**  
Trailer > yes
- **Encoding RFK\_6C (reverse camera system)**  
equipment\_ahk > installed
- **Encoding STF\_74 (chassis control system)**  
Trailer > installed
- **Encoding EPH\_76 (PDC controller)**  
Trailer > trailer device can be removed manually
- **Encoding DiS\_13 (controler distance control, possible Login 20103)**  
Control module for towing sens > installed or  
Control module for trailer recognition > installed  
(Byte 03 Bit 03)
- **Encoding FFF\_A5 (front sensor system controller)**  
AAG > coded
- **Encoding HDE\_6D (boot lid electronics controller)**  
Trailer > installed

**Important note on encoding and activating in trailer mode**

The aforementioned settings are carried out in the vehicle's electrical system and saved locally. During general updates for the vehicle software (for example, within the scope of service or repair work) the settings may be overwritten and deleted under certain circumstances. At this case, the trailer mode activation has to be updated again locally after the update. Diagnostic information relating to the trailer mode that may appear during variance comparisons with the data saved in the manufacturer's works, may form the basis of the local activation

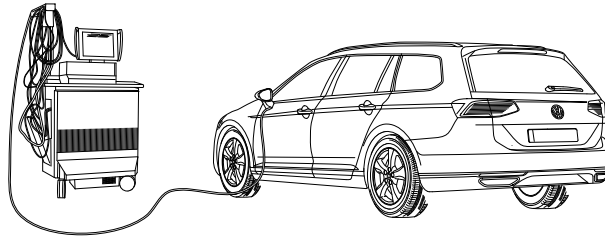

F

I

**Codage avec VCDS, attention:**

La procédure de codage ou d'activation du fonctionnement avec remorque décrite cidessous sert uniquement d'orientation générale et peut varier fortement d'un modèle a l'autre (motorisation l'équipement). Le cas échéant, il peut s'avérer nécessaire d'adapter moins ou d'autres dispositifs de commande.

- **Une fois la connexion avec VCDS établie, mettre l'appareil de commande «69 fonctionnement avec remorquen sur «codén dans \_19 la liste d'assemblage théorique**
- **Codage EZE\_09 (appareil de commande de la centrale électrique électronique; Login 31347)**  
Diagnostic / Plan de mise en réseau / Autodiagnostic  
appareil de commande, codage hitch\_ecu > installed;  
Véhicules depuis (MJ 2017 >>) Ajustement > canal  
- intégration de l'unité de remorque > installée
- **Codage ZKS\_46 (Système de commodité de module Central)** trailer monitoring > mettre actif trailer control unit > monté
- **Codage\_03 (Electronique de freinage; Login 61378)**  
Ajustement > canal – stabilisation de la remorque,  
valeur sur > activé
- **Codage SWA\_3C (l'aide au changement de voie)**  
ECU for draw bar > with ECU for draw bar
- **Codage SCH\_17 (tableau de commande insert)**  
Remorque > oui
- **Codage RFK\_6C (Système de caméra de recul)**  
equipment\_ahk > monté
- **Codage STF\_74 (Système de commande de chassis)**  
Remorque > monté
- **Codage EPH\_76 (aide au stationnement appareil de commande)**  
Remorque > dispositif de remorque; démontable a la main
- **Codage DiS\_13 (régulateur de distance appareil de commande, possibilité Login 20103)**  
Control module for towing sens > monté ou  
Control module for trailer recognition > monté  
(Byte 03 Bit 03)
- **Codierung FFF\_A5 (capteurs avant appareil de commande) AAG > coded**
- **Codage HDE\_6D (appareil de commande de l'électronique du hayon électrique)**  
Remorque > monté

**Remarque importante sur le codage ou sur l'activation du fonctionnement avec remorque**

Les réglages mentionnés ci-dessus sont effectués dans le réseau de bord du véhicule et sauvegardés localement. Lors des mises a jour générales du logiciel du véhicule (par exemple dans le cadre de travaux de maintenance ou de réparation), ces réglages peuvent dans certaines circonstances être écrasés et supprimés. Dans ce cas, l'activation du fonctionnement avec remorque doit être a nouveau actualisée localement après la mise a jour. L'activation locale peut le cas échéant être causées par des remarques de diagnostic relatives au fonctionnement avec remorque susceptibles d'être générées lors de la comparaison entre valeurs théoriques/valeurs réelles effectuée avec les valeurs conservées dans l'usine du constructeur..

**Codifica con VCDS, attenzione:**

Esercizio rimorchio descritto qui di seguito serve esclusivamente come orientamento generale e può variare radicalmente a seconda del modello (motorizzazione / dotazione). É possibile che meno o altre centraline debbano essere adeguate.

- **Dopo la connessione con VCDS, nella lista. \_19 d'installazione nominale la centralina 69 Funzione rimorchio" deve essere codificata.**
- **Codifica EZE\_09 (centralina del sistema elettrico centrale elettronico; Login 31347)**  
Schema di collegamento in rete / Autodiagnosi / centralina / codifica > hitch\_ecu > installed  
Veicolo da (MJ 2017>>) Regolazione ->canale-integrazione centralina rimorchio ->installata
- **Codifica ZKS\_46 (Sistema di convenienza di modulo centrale)**  
trailer monitoring > attivare / trailer control unit > installato
- **Codifica\_03 (Frenatura elettronica; Login 61378)**  
Regolazione > canale – stabilizzazione rimorchio,  
cambio valore su > attiv
- **Codifica SWA\_3C (Cambio corsia Assist)**  
ECU for draw bar > with ECU for draw bar
- **Codifica SCH\_17 (Inserito cruscotto)**  
Trailer > si
- **Codifica RFK\_6C (sistema di telecamere retromarcia)**  
equipment\_ahk > installato
- **Codifica STF\_74 (sistema di controllo del telaio)**  
Rimorchio > installato
- **Codifica EPH\_76 (centralina ausilio di parcheggio)**  
Rimorchio > dispositivo rimorchio rimovibile manualmente
- **Codifica DiS\_13 (centralina regolazione distanza, possibile Login 20103)**  
Control module for towing sens > installato o  
Control module for trailer recognition > installato  
(Byte 03 Bit 03)
- **Codifica FFF\_A5 (centralina sensori frontali)**  
AAG > coded
- **Codifica HDE\_6D (centralina sistema elettronico coperchio portabagagli)**  
Rimorchio > installato

**Avvertenza importante per la codifica\_ o. l'attivazione per funzionamento con rimorchio**

Le impostazioni indicate in precedenza vengono effettuate nella rete di bordo del veicolo memorizzate localmente. Nel caso di update generalidei software del veicolo (ad esempio nell'ambito dei lavori di assistenza e messa a punto), in part1colan circostanze é possibile sovrascrivere e cancellare nuovamente queste impostazioni. In questo caso dopo l'update deve essere nuovamente aggiornata localmente l'attivazione per funzionamento con rimorchio. Le avvertenze di diagnosi in riferimento al funzionamento con rimorchio, generate durante una comparazione dei valori nominali/effettivi con i dati inseriti in fabbrica dal costruttore, potrebbero dipendere dall'attivazione locale

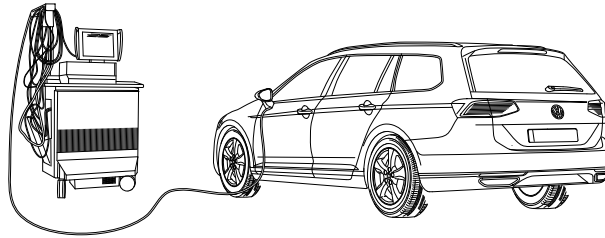

E

NL

**Codificación de noc VCDS, por favor, tener en cuenta**

El proceso descrito codificación para la codificación y/o habilitación para el servicio con remolque sólo sirve para una orientación general y puede variar considerablemente dependiendo del modelo (motorización/equipamiento). En caso dado puede que tengan que adaptarse menos u otros reguladores.

- **Después de haber establecido la conexión con VCDS se deberá ajustar el controlador 69 función de remolque" en \_19 la lista de dispositivos a codificar**
- **Codificación EZE\_09 (controlador del sistema eléctrico central electrónico; Login 31347)**  
Esquema de interconexión / Autodiagnos del controlador  
Codificación hitch\_ecu > installed;  
Vehículos desde (MJ 2017 >>) Adaptación -> canal  
- integración de la unidad de remolque -> instalada
- **Codificación ZKS\_46 (Sistema de confort de módulo central) trailer monitoring > poner en activo trailer control unit > montado**
- **Codificación \_03 (Frenos Electrónica; Login 61378)**  
Adaptación > canal - estabilización del remolque,  
valor en > activado
- **Codificación SWA\_3C (asistente de cambio de caml)**  
ECU for draw bar > with ECU for draw bar
- **Codificación SCH\_17 (Cuadro de instrumentos)**  
Trailer > si
- **Codificación RFK\_6C (sistema de cámara de reversa)**  
equipment\_ahk > montado
- **Codificación STF\_74 (sistema de control de chasis)**  
Remolque > montado
- **Codificación EPH\_76 (controlador del sistema de ayuda al aparcamiento) desmontable a mano**
- **Codificación DiS\_13 (controlador del sistema de regulación de distancia, Login de acceso posible 20103)**  
Control module for towing sens > montado o  
Control module for trailer recognition > montado  
(Byte 03 Bit 03)
- **Codificación FFF\_A5 (controlador del sistema de sensores frontales) AAG > coded**
- **Codificación HDE\_6D (controlador del sistema electrónico de la puerta del maletero)**  
Remolque > montado

**Nota importante sobre la codificación y/o habilitación del modo remolque**

Los ajustes anteriormente mencionados se llevan a cabo en el sistema eléctrico de a bordo y se guardan de forma local. Al realizar actualizaciones generales de software del vehículo (por ejemplo con motivo de trabajos de mantenimiento o reparación) es posible que estos ajustes se vuelvan a borrar y sobrescribir. En tal caso se deberá volver a actualizar la habilitación del modo remolque de forma local después de la actualización. Los avisos de diagnosis relacionados con el modo remolque, que puedan aparecer en caso de comparación de datos teóricos/reales con los datos depositados en la fábrica, se pueden deber a la habilitación local

**Codering met VCDS, let op a.u.b.:**

Het hieronder omschreven proces voor de codering van de aanhangwagen functie dient uitsluitend ter algemene oriëntatie en kan afhankelijk van model (motorisering / uitvoering) sterk variëren. Indien nodig, moeten mindere of andere besturingsapparaten worden aangepast.

- **Na aansluiting met het on board diagnostisch systeem VCDS moet in de \_19 installatie lijst, de regeleenheid '69- aanhangwagenfunctie' worden ingesteld als zijnde 'gecodeerd'.**
- **Codering EZE\_09 (Aansturingsapparaat voor .de elektronische centrale elektriciteitsvoorzienng; Login 31347)**  
Diagnose Aansluitingsdiagram / Zelfdiagnose van de controller / Coderen hitch\_ecu > installed  
Voertuigen vanaf (MY 2017>>) Wijziging – kanaal  
Integreren trailer controle unit – geïnstalleerd
- **Codering ZKS\_46 (Centrale module gemak systeem) trailer monitoring > gezet op actief trailer control unit > geïnstalleerd**
- **Codering \_03 (Rem electronica; Login 61378)**  
Wijziging > Kanaal – trailer stabilisatie, wijzig waarde naar > actief
- **Codering SWA\_3C (Rijstrookwisselhulp)**  
ECU for draw bar > with ECU for draw bar
- **Codering SCH\_17 (Inzetstuk Dash)**  
Trailer > ja
- **Codering RFK\_6C (achteruitrijcamera systeem) equipment\_ahk > geïnstalleerd**
- **Codering STF\_74 (chassis controlesysteem) aanhanger > geïnstalleerd**
- **Codering EPH\_76 (controller parkeersysteem) aanhanger > aanhangerunit handmatig losse koppelen**
- **Codering DiS\_13 (controller automatische afstandscontrole, mogelijke Login 20103)**  
Control module for towing sens > geïnstalleerd of  
Control module for trailer recognition > geïnstalleerd  
(Byte 03 Bit 03)
- **Codering FFF\_A5 (controller sensoren voorzijde) AAG > coded**
- **Codering HDE\_6D (controller achterklepelectronica) Aanhanger > geïnstalleerd**

**Belangrijke aanwijzing voor het coderen, dan wel deblokken van het aanhangerbesturingsysteem**

De eerder genoemde instellingen worden uitgevoerd op de boordcomputer van uw voertuig en ze worden lokaal opgeslagen. Het is echter mogelijk dat bij een algemene update van uw voertuigsoftware (bijvoorbeeld in het kader van een servicebeurt Of tijdens herstelwerkzaamheden ) uw instellingen onder bepaalde omstandigheden worden overgeschreven dan wel gewist. In dat geval moet de deblokken van het aanhangerbesturingsysteem na de update nog een keer lokaal worden geactualiseerd. Eventueel kunnen er diagnostische instructies/meldingen ten aanzien van het aanhangerbesturingsysteem worden gegenereerd door het feit dat er lokaal wordt gedeblokkeerd - die situatie kan zich voordoen wanneer de fabrieksinstellingen worden gebruikt in vergelijkingen tussen een actuele en een gewenste situatie

## Diagnostic System

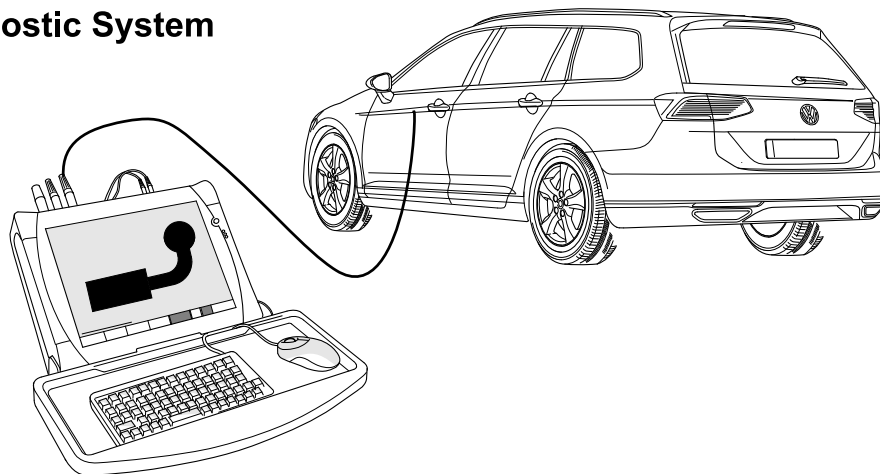

D	GB	F
<p><b>Die Aktivierung der Anhängerfunktionen im Fahrzeug wird hier beispielhaft an einem Diagnose-System Hella Gutmann mega macs PC (V52) beschrieben:</b></p> <ol style="list-style-type: none"> <li>1. Fahrzeugauswahl</li> <li>2. In Diagnose wechseln-Kodierung</li> <li>3. Anhängerkupplung de-/aktivieren</li> <li>4. Diagnose Interface Bus auswählen</li> <li>5. Anleitung folgen</li> </ol> <p><b>Fahrzeuge mit Assistenzsystemen:</b></p> <ol style="list-style-type: none"> <li>6. AHK an Assistenzsysteme anpassen ausführen</li> <li>7. Anleitung folgen</li> <li>8. Diagnose</li> <li>9. Fehlerspeicher auslesen, ggf. löschen</li> </ol>	<p><b>Activation of the vehicle's trailer features is described here with the example of a Hella Gutman mega macs PC (V52) diagnostic system:</b></p> <ol style="list-style-type: none"> <li>1. Select vehicle</li> <li>2. Switch to diagnosis - coding</li> <li>3. (De)activate trailer coupling</li> <li>4. Select Diagnose interface bus</li> <li>5. Follow instructions</li> </ol> <p><b>Vehicles with Advanced Driver Assistance Systems:</b></p> <ol style="list-style-type: none"> <li>6. Execute Match trailer coupling with assistance system</li> <li>7. Follow instructions</li> <li>8. Diagnosis</li> <li>9. Read-out error memory, delete, if necessary</li> </ol>	<p><b>L'activation des fonctions de remorque du véhicule est décrite ici à titre d'exemple sur un système de diagnostic Hella Gutmann mega macs PC (V52) :</b></p> <ol style="list-style-type: none"> <li>1. Sélectionner le véhicule</li> <li>2. Codage passer en mode diagnostic</li> <li>3. Désactiver/activer l'attelage de remorque</li> <li>4. Sélectionner interface bus diagnostic</li> <li>5. Suivre les instructions</li> </ol> <p><b>Véhicules avec systèmes d'assistance :</b></p> <ol style="list-style-type: none"> <li>6. Exécuter l'adaptation de l'attelage de remorque sur les systèmes d'assistance</li> <li>7. Suivre les instructions</li> <li>8. Diagnostic</li> <li>9. Lire, le cas échéant, supprimer la mémoire des défauts</li> </ol>
I	E	NL
<p><b>L'attivazione delle funzioni rimorchio sull'autoveicolo è descritta qui, a titolo esemplificativo, su un sistema diagnostico Hella Gutmann mega macs PC (V52):</b></p> <ol style="list-style-type: none"> <li>1. selezione autoveicolo</li> <li>2. in diagnosi variazione codifica</li> <li>3. disattiva/attiva gancio rimorchio</li> <li>4. selezionare interfaccia bus diagnosi</li> <li>5. seguire le istruzioni</li> </ol> <p><b>Autoveicoli con sistemi di assistenza:</b></p> <ol style="list-style-type: none"> <li>6. eseguire adeguamento gancio rimorchio su sistemi di assistenza</li> <li>7. seguire le istruzioni</li> <li>8. diagnosi</li> <li>9. leggere, event. cancellare la memoria errori</li> </ol>	<p><b>La activación de las funciones de remolque en el vehículo se describe en este caso a modo de ejemplo en un sistema de diagnóstico Hella Gutmann mega macs PC (V52):</b></p> <ol style="list-style-type: none"> <li>1. Selección de vehículo</li> <li>2. Cambiar a codificación de diagnóstico</li> <li>3. De/activar el enganche del remolque</li> <li>4. Seleccionar el bus de interfaz de diagnóstico</li> <li>5. Seguir las instrucciones</li> </ol> <p><b>Vehículos con sistemas de asistencia:</b></p> <ol style="list-style-type: none"> <li>6. Adaptar AHK a los sistemas de asistencia</li> <li>7. Seguir las instrucciones</li> <li>8. Diagnóstico</li> <li>9. Leer la memoria de fallas, eliminar si es necesario</li> </ol>	<p><b>De activering van de aanhangervuncties in het voertuig wordt hier aan de hand van bijvoorbeeld een Hella Gutmann mega macs PC (V52) beschreven:</b></p> <ol style="list-style-type: none"> <li>1. Selectie van voertuig</li> <li>2. In diagnose veranderen-codering</li> <li>3. Aanhangwagenkoppeling deactiveren/activeren</li> <li>4. Diagnose interface bus kiezen</li> <li>5. Instructie opvolgen</li> </ol> <p><b>Voertuigen met hulpsystemen:</b></p> <ol style="list-style-type: none"> <li>6. AHK aan hulpsystemen aanpassen uitvoeren</li> <li>7. Instructie opvolgen</li> <li>8. Diagnose</li> <li>9. Foutgeheugen uitlezen, evt. wissen</li> </ol>

60

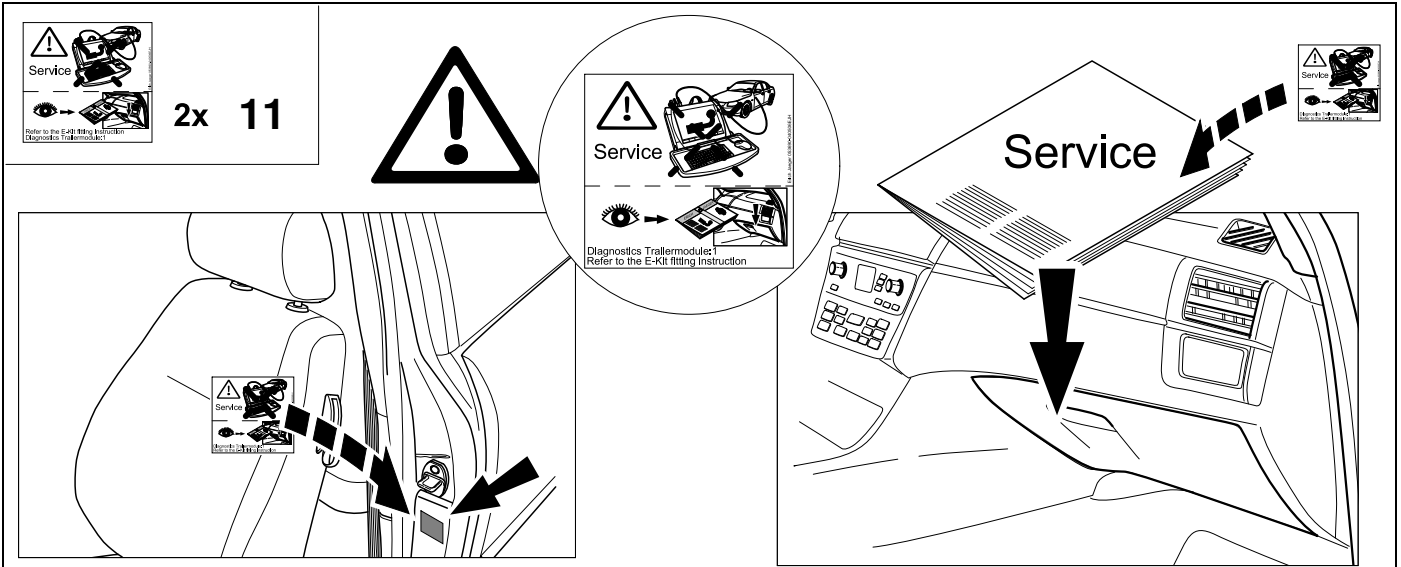

61 OPTIONAL



**BRINK**

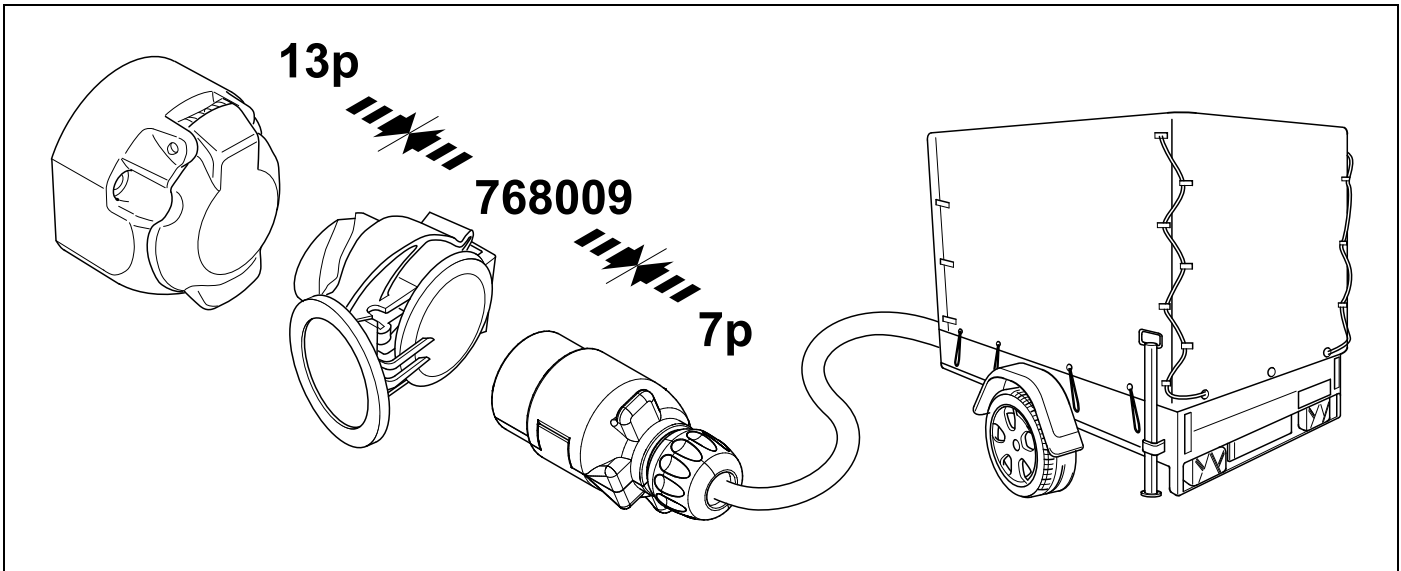

62 PLEASE NOTICE

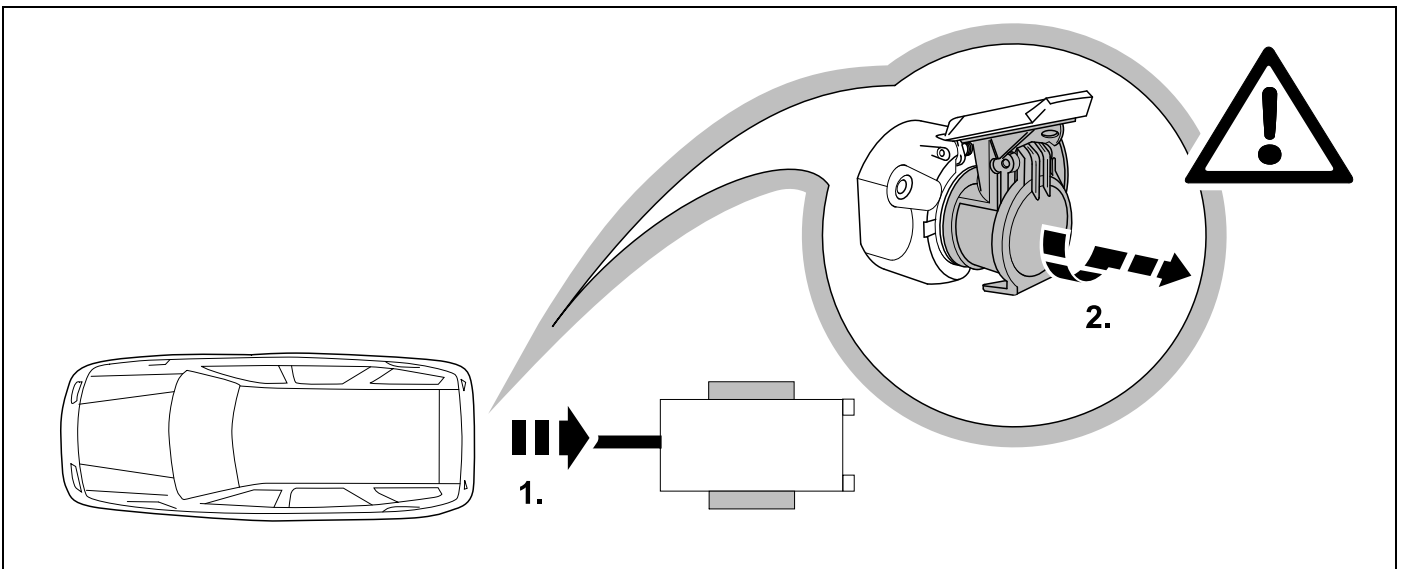

# Status LED für Eigendiagnose

# Status LED for self-diagnosis

## Operation support

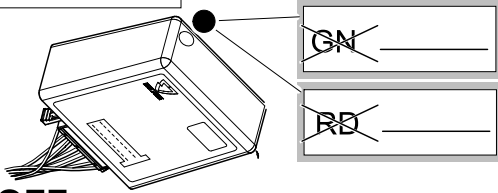
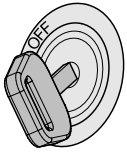

No CAN-Data =



Standby / Sleepmode

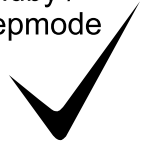

Ignition OFF

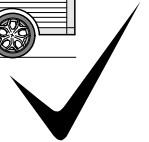
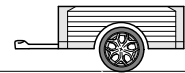
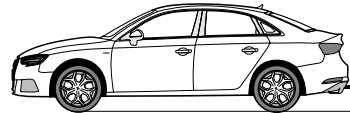
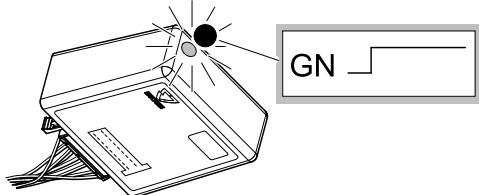

Ignition ON

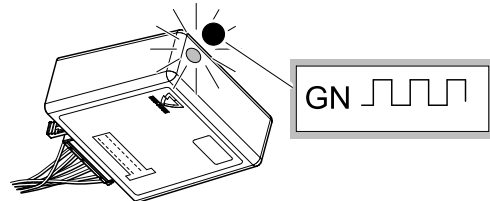

Ignition ON

## Failure support

CAN-Data Wire



1x max. 5 min.

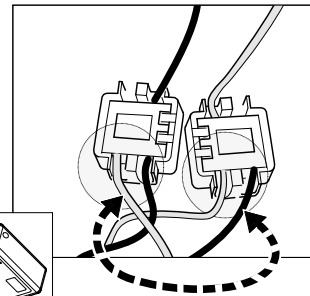
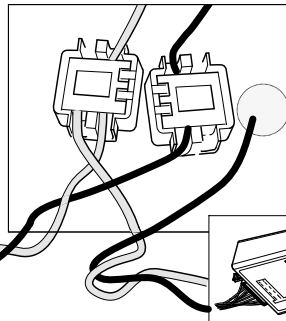
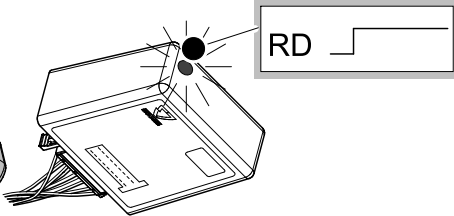

Ignition ON

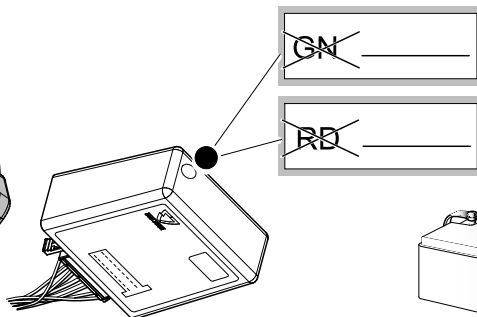
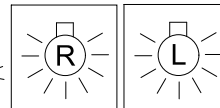

PIN 17 oder / or



PIN 1

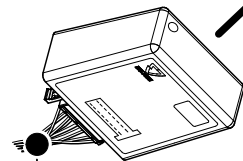
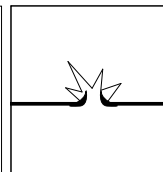
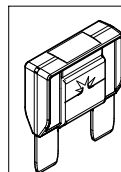
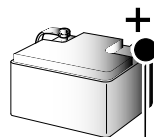

Ignition ON









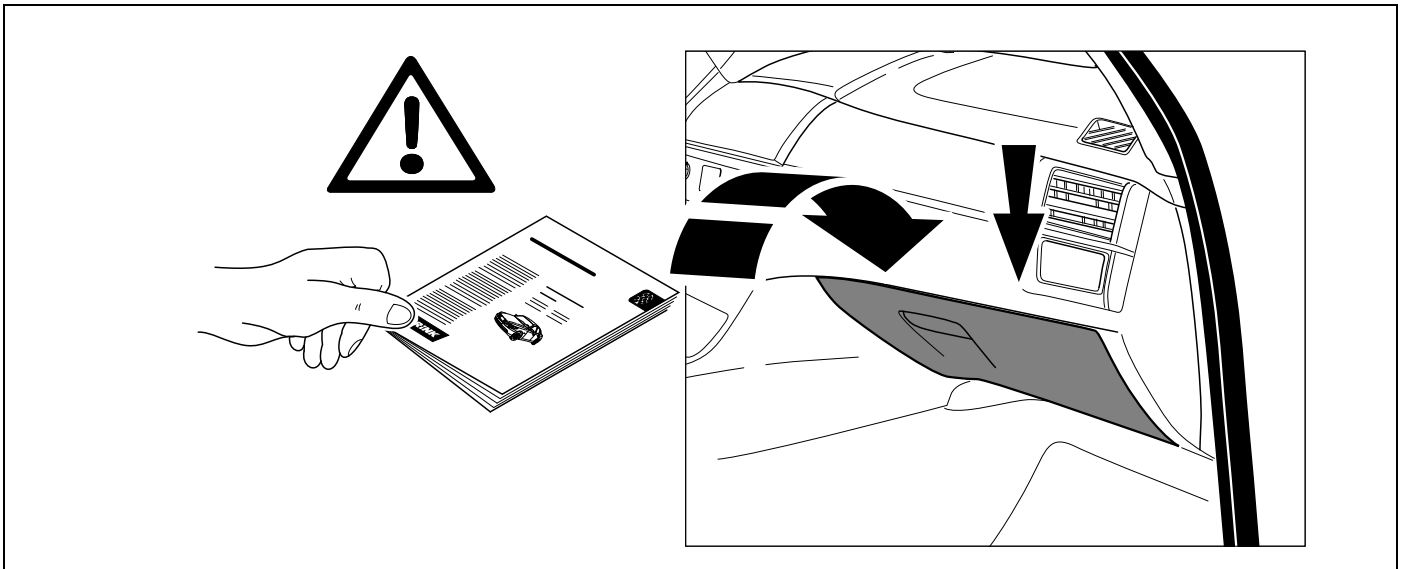

<p><b>D</b> Änderungen bezüglich Konstruktion, Ausstattung Farbe sowie Irrtum vorbehalten. Angaben und Abbildungen unverbindlich</p>	<p><b>PL</b> Zastrzega się prawo do zmian dot. konstrukcji, wykończenia, kolorystyki oraz pomyłek. Dane i ilustracje niewiążące.</p>
<p><b>GB</b> Subject to change in terms of construction, equipment and colour, and may contain errors. The information and illustrations are non-binding.</p>	<p><b>TR</b> Tasarım, donanım ve renk bakımından değişiklik yapma hakkı ve hata ve eksiklik mahfuzdur. Veriler ve resimler bağlayıcı değildir.</p>
<p><b>F</b> Sous réserve de modifications de la construction, de équipement, de la couleur et sous réserve d'erreurs. Les indications et les illustrations sont sans engagement.</p>	<p><b>H</b> A szerkezet, a kivitelt és a szín változtatása, valamint a változások joga fenntartva. Az adatok és az ábrák nem kötelező érvényűek.</p>
<p><b>NL</b> Wijzigingen met betrekking tot constructie, uitvoering en kleur evenals vergissingen voorbehouden. Gegevens en afbeeldingen niet bindend.</p>	<p><b>HR</b> Pravo promjena u svezi konstrukcije, opreme, boje kao i zabune oridžavamo. Podaci i ilustracije su neobavezne.</p>
<p><b>DK</b> Ændringer med hensyn til konstruktion, udstyr, farver samt fejl forbeholdes. Oplysninger og illustrationer er uforpligtende.</p>	<p><b>BUL</b> Запазени права по отношение на конструкцията, обзавеждането, цвета и грешки. Данните и изображенията не са обвързващи.</p>
<p><b>N</b> Endringer angående konstruksjon, utstyr, farge og feiltagelse forbeholdes. Opplysninger og illustrasjoner uforbindtlig.</p>	<p><b>RO</b> Ne rezervăm dreptul unor modificări ale construcției, dotării, culorii și dreptul la erori Datele indicate și imaginile sunt orientative.</p>
<p><b>S</b> Med reservation för ändringar vad det gäller konstruktion, utrustning, färg samt för misstag. Uppgifterna och bilderna är inte bindande.</p>	<p><b>RU</b> Права на внесение изменений относительно конструкции, оснащения, окраски, а также на ошибки сохраняются. Данные и иллюстрации имеют примерный характер.</p>
<p><b>FIN</b> Pidätämme oikeuden rakennetta, varustusta, väriä koskeviin sekä erehdyksestä johtuviin muutoksiin. Tiedot ja kuvat eivät ole sitovia.</p>	<p><b>LT</b> Pasiliekaama konstrukcijos, įrangos bei reikmenų, spalvos pakeitimų ir klaidų teisė. Duomenys ir iliustracijos neįpareigojantys.</p>
<p><b>I</b> Con riserva di modifiche relative a progettazione, dotazione, colore ed errori. Le indicazioni e figure sono fornite senza impegno.</p>	<p><b>LV</b> Tiek paturētas tiesības uz konstrukcijas, iekārtu, krāsu izmaiņām, kā arī kļūdīšanās. Dati un attēli bez saistībām.</p>
<p><b>E</b> Reservadas las modificaciones respecto a diseño, equipamiento, color, así como error. Indicaciones y figuras sin compromiso.</p>	<p><b>EST</b> Konstruktsiooni, varustuse ja võevi osas muudatused ning eksimine lubatud. Andmed ja joonised on mittesiduvad.</p>
<p><b>P</b> Reservamos o direito de alterações relativamente ao desenho, equipamento, cor, bem como de erro. Os dados e as gravuras não implicam compromisso da nossa parte.</p>	<p><b>SLO</b> Zadržana pravica do sprememb glede konstrukcije, opreme, barve ter pomote. Podatki in slike so neobvezne.</p>
<p><b>GR</b> Διατηρώνουμε κάθε επιφύλαξη ως προς αλλαγές σε σχέση με κατασκευή, εξοπλισμό, διαρρυθμίση, χρωματισμούς και λάθη παραδρομής.</p>	<p><b>SK</b> Zmeny, ktoré sa týkajú konštrukcie, vybavenia, farby, ako aj omyly sú vyhradené. Údaje a zobrazenia sú nezáväzné.</p>
<p><b>CZ</b> Změny, týkající se konstrukce, vybavení, barvy, jakož i omyly jsou vyhrazeny. Údaje a vyobrazení jsou nezávazné.</p>	