

# Wiringkit

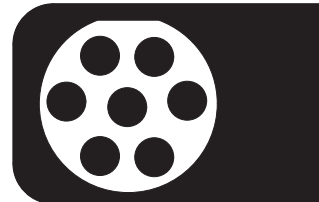

- D Einbauanleitung
- GB Installation instructions
- F Consignes de montage
- NL Montagehandleiding
- DK Montagevejledning
- N Monteringsinstruksjon
- S Installationsanvisning
- FIN Asennusohje
- I Istruzioni per il montaggio
- E Instrucciones de montaje
- P Instruções de montagem
- GR Οδηγίες εγκατάστασης
- CZ Návod k montáži
- SLO Navodilo za vgradnjo
- SK Montážny návod
- PL Instrukcja montażu
- TR Montaj talimatı
- H Beépítési útmutató
- HR Upute o ugradnji
- BUL Инструкция за монтаж
- RO Instrucțiuni de montaj
- RU Инструкция по монтажу и установке
- LT Montavimo informacija
- LV Iemontēšanas pamācība
- EST Paigaldusjuhend

## 727763 Mercedes Benz

- C-Class W205 Saloon 03/2014 >> 06/2018
- C-Class S205 Estate 09/2014 >> 06/2018
- C-Class C205 Coupe 12/2015 >> 06/2018
- C-Class A205 Cabriolet 07/2016 >> 06/2018

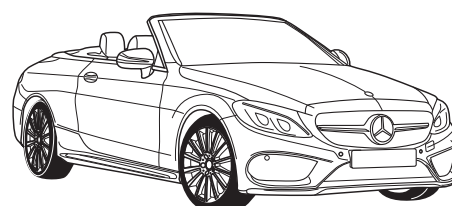
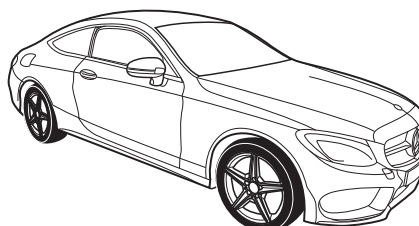
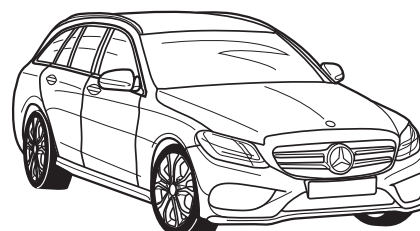
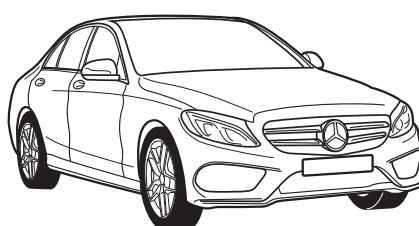
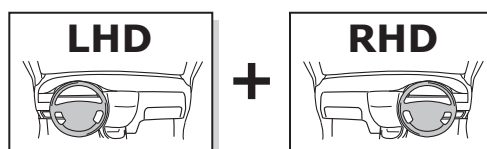

**DE** • Einbauanleitung Elektrosatz Anhängervorrichtung mit 12-N Steckdose lt. DIN/ISO Norm 1724. • Wir weisen ausdrücklich darauf hin, dass eine unsachgemäße und nicht in einer Fachwerkstatt durchgeführte Montage einen Verzicht auf Entschädigung jeglicher Art insbesondere bezüglich des Produkthaftpflichtrechts zur Folge hat. • Technische Änderungen vorbehalten. • Widerstand nur gemäß der Tabelle auf dem Anhänger verwenden. • Bei Funktionsproblemen ist die Fehlersuche auf ca. 0,5 Stunden zu begrenzen.

**FR** • Instructions de montage du faisceau électrique pour crochet d'attelage conforme à la norme DIN/ISO 1724 prise 12-N. • Il est expressément prévu qu' on ne saurait se prévaloir d'un quelconque préjudice contractuel ou réhibitoire si le montage avait été fait en dépit des dites instructions ou dans un garage ne disposant pas des équipements adéquats. • Sous réserve de modifications techniques. • Ne excédez pas la charge maximale, indiquée dans le tableau. • S'il y a des problèmes de fonctionnement, limiter la recherche de défauts à env. 30 minutes.

**NL** • Montage-handleiding elektrokabelset voor trekhaak met 12-N contactdoos vlg. DIN/ISO norm 1724. • Wij wijzen er met nadruk op, dat ondeskundige en niet door een vakkundige werkplaats uitgevoerde montage tot gevolg heeft dat daardoor ieder recht op schadevergoeding, ook op wettelijke aansprakelijkheid inzake producten, vervalt. • Technische wijzigingen voorbehouden. • Gebruik alleen belasting volgens aansluittabel op het getrokken voertuig. • Bij werkingsproblemen moet de foutencontrole tot ca. 0,5 uur beperkt worden.

**GB** • Fitting instructions electric wiring kit tow bar with 12-N socket up to DIN/ISO Norm 1724. • We would expressly point out that assembly not carried out properly by a competent installer will result in cancellation of any right to damage compensation, in particular those arising by virtue of the product liability act. • Contents of these kits and their fitting manuals are subject to alteration without notice, please ensure that these instructions are read and fully understood before commencing installation. • Do not overload circuits; the maximum loads per connection are detailed in this manual. • In the event of functional problems, troubleshooting must be limited to about 0.5 hours.

**ES** • Instrucciones de montaje de kit eléctrico para enganche de remolque con caja de conexiones 12-N según norma DIN/ISO 1724. • El montaje inapropiado y efectuado por personal no cualificado originará la pérdida de todo derecho a indemnización o la expiración de toda responsabilidad civil con respecto al producto. • Nos reservamos el derecho a efectuar modificaciones técnicas. • Utilice sólo cargas de acuerdo a la tabla de conexión del vehículo remolcado. • En caso de tener problemas con su funcionamiento, la búsqueda de errores está limitada a aprox. 0,5 horas.

**IT** • Istruzioni di montaggio di set di cavi elettrici per gancio da traino con zoccolo a 12 N conforme alla norma DIN/ISO 1724. • Sottolineiamo espressamente che un montaggio inadeguato ed eseguito da un'officina non specializzata ha come conseguenza il decadere di qualsiasi diritto al risarcimento danni, nonché alla responsabilità legale relativa ai prodotti. • Ci si riserva il diritto di apportare modifiche tecniche. • Utilizzare esclusivamente un carico conforme alla tabella degli allacci relativa al veicolo in questione. • In caso di problemi di funzionamento, la ricerca di errori dovrebbe essere limitata a circa 0,5 ore.

**SE** • Monteringsanvisningar elkabelsats för dragkrok med 12-N kontaktdosa enligt DIN/ISO norm 1724. • Vi påpekar med eftertryck att all rätt till skadeersättning och all laglig ansvarighet förfaller om monteringen inte har utförts på rätt sätt och av en professionell verkstad. • Tekniska ändringar förbehålles. • Använd endast belastning enligt anslutningstabellen på det dragna fordonet. • Vid funktionsproblem ska felsökningen begränsas till ca 0,5 timme.

**CZ** • Montážní pokyny: souprava pro elektrické propojení tažné tyče s 12 - N zásuvkou do normy DIN/ISO 1724. • Výslovně zdůrazňujeme, že jakákoli montáž, která není provedená ve specializované dílně, má za - následek odvolání nároku na kompenzaci jakéhokoli druhu, obzvláště vyplývajících ze zákona o odpovědnosti za způsobené škody. • Změny mohou být provedeny bez oznámení. • Používejte pouze při maximálním nabití podle tabulky na tažném vozidle. • Při problémech funkčnosti je třeba vyhledávání chyb omezit na cca 0,5 hodiny.

**DK** • Monteringsvejledninger for det elektriske ledningsføringssæt for trækstang med 12-N stikdåse, DIN/ISO, norm 1724. • Vi ønsker at gøre udtrykkeligt opmærksom på atforkert samling, der ikke er udført af et specialiseret værksted, resulterer i bortfaldelse af kompenseringskrav af alle slags, i særdeles krav der måtte opstå omkring det lovpålagte ansvar. • Kan ændres uden varsel. • Brug kun den maksimale belastning, i overensstemmelse med forbindelsestabellen for bugserede køretøjer. • Ved funktionsproblemer skal fejlsøgningen begrænses til ca. 0,5 time.

**FI** • Ohjeet vetokoukun sähkökaapelisarjan asentamiseen, jossa on DIN/ISO 1724 mukainen 12-N liitin. • Korostamme, että kaikki oikeudet vahinkokorvaukseen kuten myös valmistajan laillinen vastuu raukeavat, mikäli asennusta ei ole toteutettu oikealla tavalla eikä ammattitaitoisen asiantuntijan toimesta. • Oikeus teknisiin muutoksiin ilman erillistä huomautusta pidätetään. • Kuormita työvirtapiiriä ainoastaan hinattavan ajoneuvon kytkentäkaavion mukaisesti. • Virrehaku on rajoitettava toiminto-ongelmien esiintyessä noin 0,5 tuntiin.

**GR** • Οδηγίες συναρμολόγησης ηλεκτρικού σετ καλωδίων μπάρας ρυμούλκησης με υποδοχή 12-N μέχρι DIN/ISO Κανόνας 1724. • Επισημαίνουμε κατηγορηματικά ότι οποιαδήποτε εσφαλμένη συναρμολόγηση, η οποία δεν έχει πραγματοποιηθεί ειδικό εργαστήριο θα οδηγήσει σε αποποίηση των αξιώσεων επιβολής αποζημιώσεων οποιοδήποτε είδους, ειδικά όσα προκύπτουν από το νόμο ευθύνης προϊόντων. • Μπορεί να τροποποιηθεί χωρίς προηγούμενη ειδοποίηση. • Χρησιμοποιείτε μόνο μέγιστο ηλεκτρικό φορτίο σύμφωνα με τον πίνακα σύνδεσης στο ρυμουλκούμενο όχημα. • Σε περίπτωση προβλημάτων λειτουργίας να περιοριστεί η αναζήτηση σφαλμάτων σε περ. 0,5 δευτ.,.

**NO** • Monteringsanviser elkabelsett for trekkrok med 12-N koblingsboks ifølge DIN/ISO norm 1724. • Vi påpeker ettertrykkelig at all rett til skadeerstatning og rettslig ansvar forfaller dersom monteringen ikke er blitt utført på riktig måte og av et profesjonelt verksted. • Tekniske endringer forbeholdes. • Overskrid ikke grensene anvist i tilkoblingstabellen på tilhengeren eller det tilkoblede kjøretøyet. • Ved funksjonsproblemer må feilsøket begrenses til ca. 0,5 timer.

• Instrukcje montażu zestawu okablowania elektrycznego dyszla holowniczego z 12-N stykowym gniazdem DIN/ISO 1724. • Chcielibyśmy wyraźnie zaznaczyć, iż wszelki nieprawidłowy montaż, który nie jest wykonywany w specjalistycznym warsztacie pociąga za sobą utratę możliwości dochodzenia wszelkiego typu roszczeń, w szczególności tych wynikających z odpowiedzialności producenta za swój produkt. • Podlega zmianom bez powiadomienia. • Używać tylko takiego maksymalnego obciążenia które wynika z tabliczki połączeń holowanego pojazdu. • W przypadku problemów ograniczyć wyszukiwanie błędów do ok. 0,5 godziny.

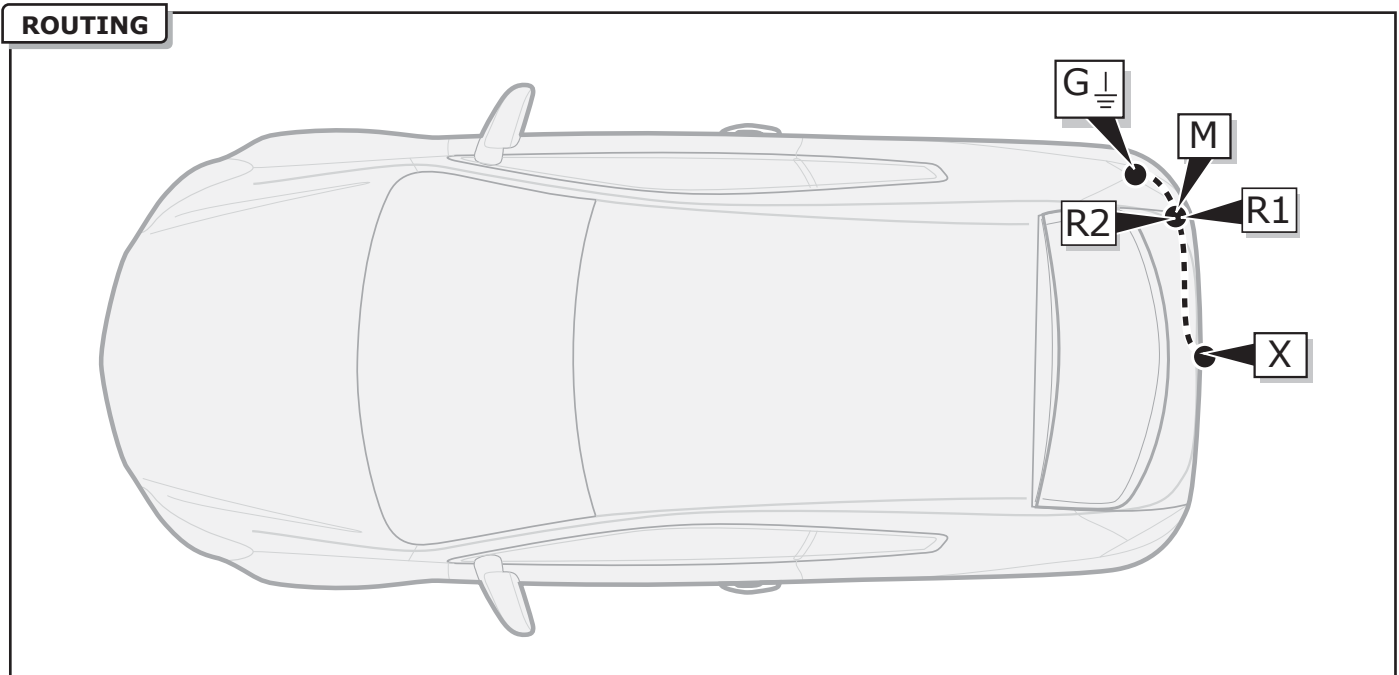
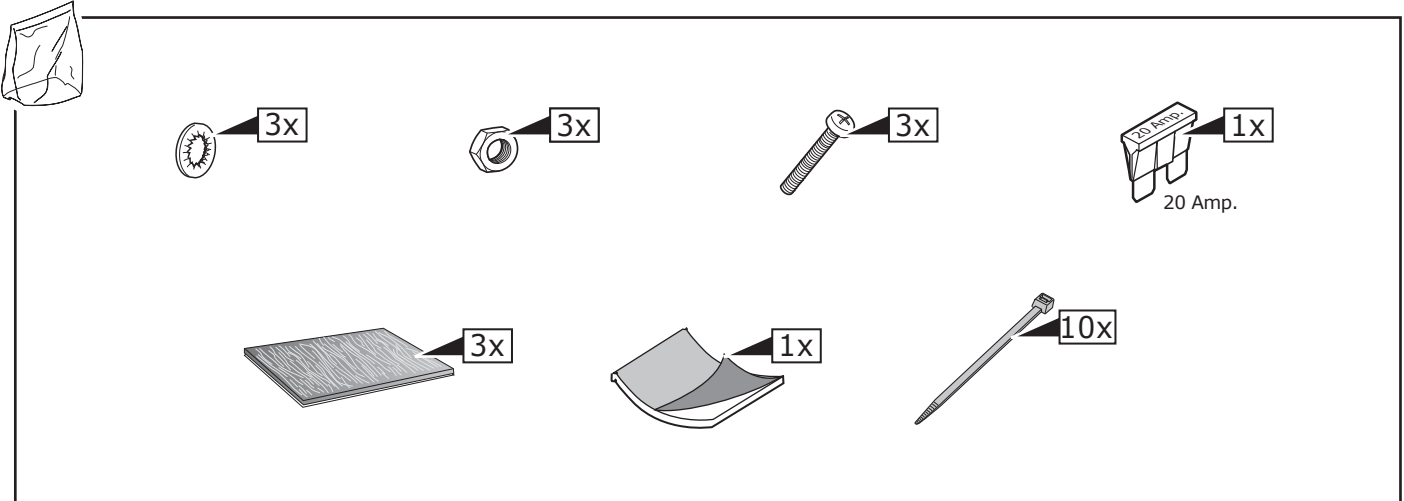
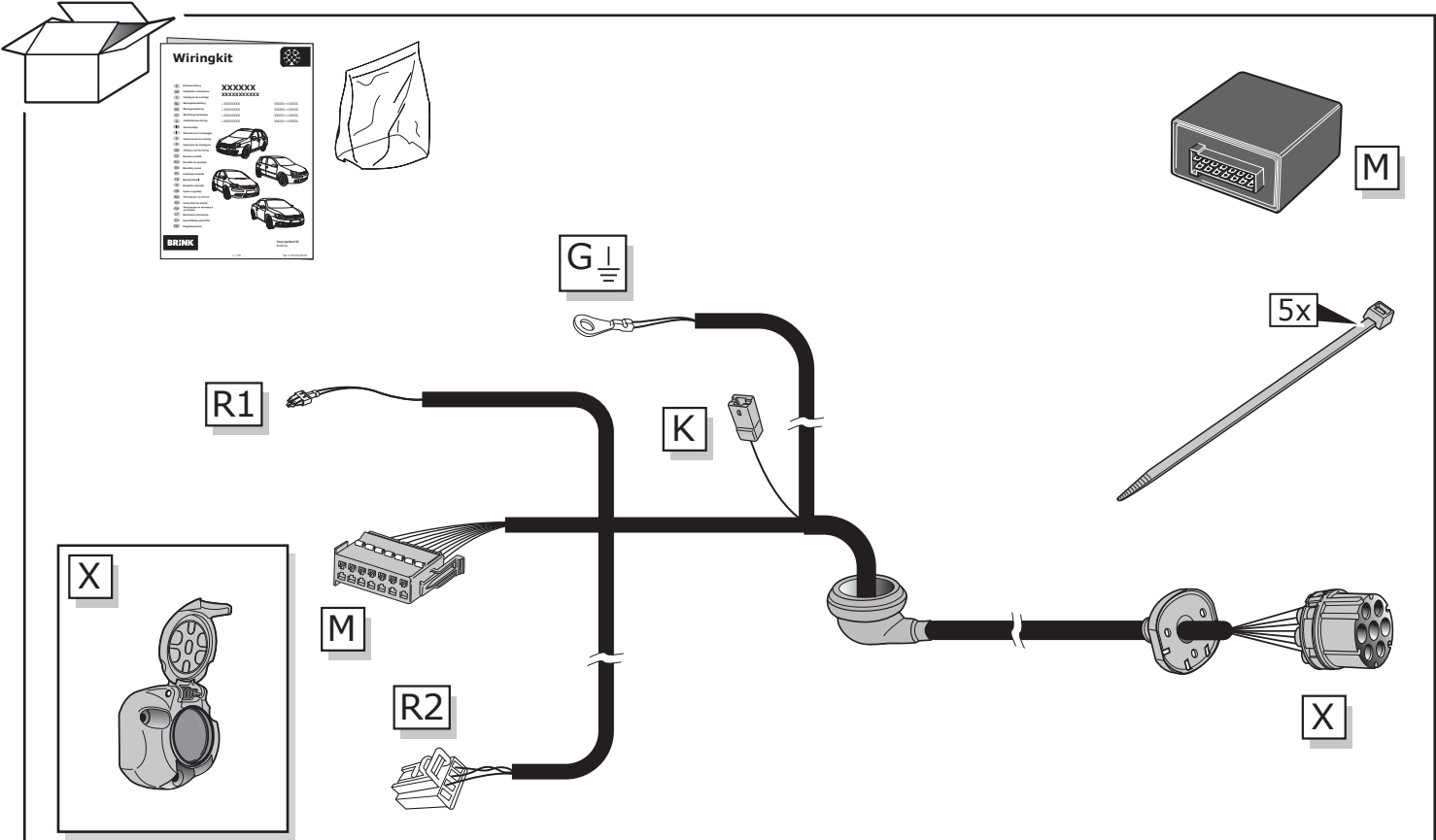

**INFO**

	BK	BN	BU	GY	GN	WH	YE	OG	PE	PI	RD
DE	Schwarz	Braun	Blau	Grau	Grün	Weiß	Gelb	Orange	Violett	Rosa	Rot
FR	Noir	Marron	Bleu	Gris	Vert	Blanc	Jaune	Orange	Violet	Pink	Rouge
NL	Zwart	Bruin	Blauw	Grijs	Groen	Wit	Geel	Oranje	Paars	Roze	Rood
GB	Black	Brown	Blue	Grey	Green	White	Yellow	Orange	Purple	Pink	Red
ES	Negro	Marrón	Azul	Gris	Verde	Blanco	Amarillo	Naranja	Morado	Rosa	Rojo
IT	Nero	Marrone	Blu	Grigio	Verde	Bianco	Giallo	Arancione	Viola	Rosa	Rosso
SE	Svart	Brun	Blå	Grå	Grön	Vit	Gul	Orange	Lila	Rosa	Röd
CZ	Černá	Hnědá	Modrá	Šedá	Zelená	Bílá	Žlutá	Oranžová	Fialová	Růžová	Červená
DK	Sort	Brun	Blå	Grå	Grøn	Hvid	Gul	Orange	Lilla	Pink	Rød
FI	Musta	Ruskea	Sininen	Harmaa	Vihreä	Valkoinen	Keltainen	Oranssi	Purppura	Vaaleanpunainen	Punainen
GR	Μαύρο	Καφέ	Μπλε	Γκρι	Πράσινο	Λευκό	Κίτρινο	Πορτοκαλί	Μοβ	Ροζ	Κόκκινο
NO	Svart	Brun	Blå	Grå	Grønn	Hvit	Gul	Oransje	Lilla	Rosa	Rød
PL	Czarny	Brązowy	Niebieski	Szary	Zielony	Biały	Żółty	Pomarańczowy	Purpurowy	Różowy	Czerwony

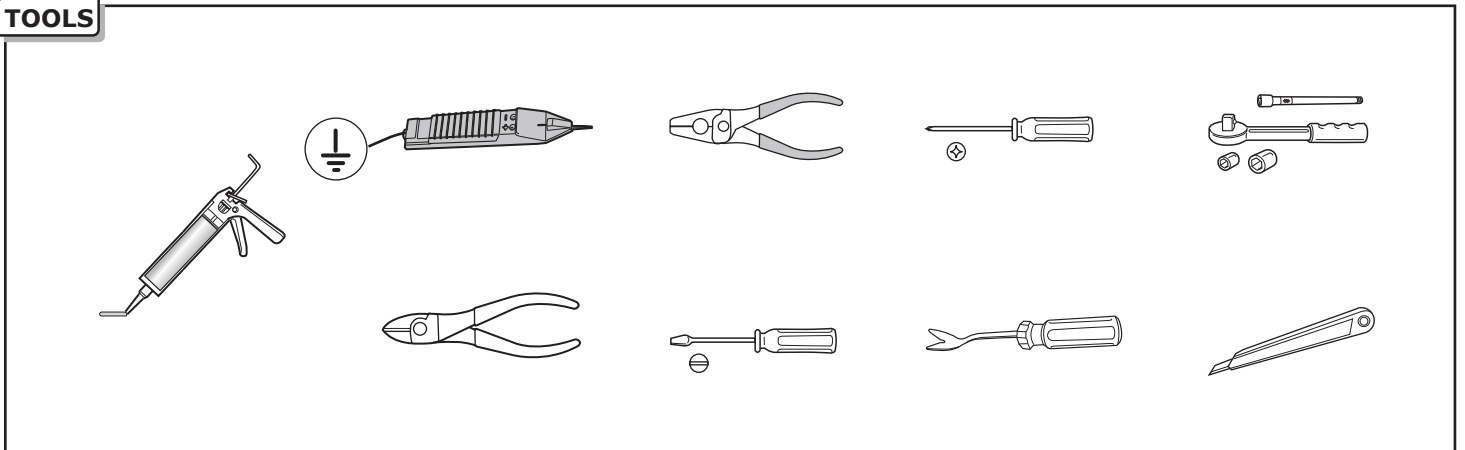
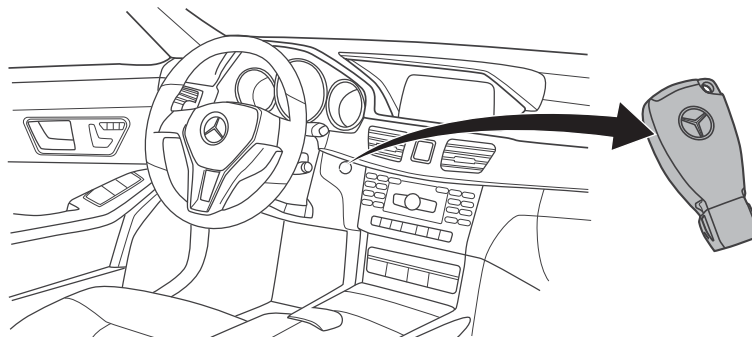
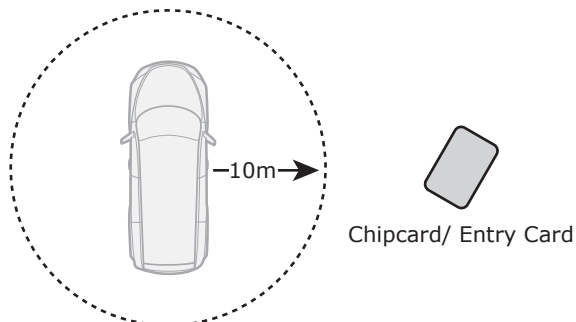
**TOOLS**

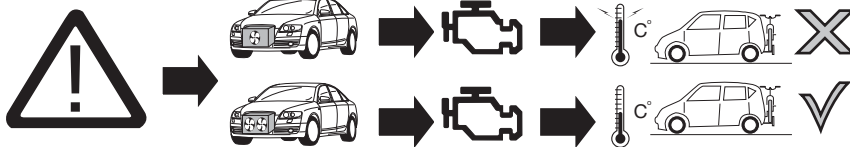
**1**

**2**
**Keyless-go**

**ACHTUNG!**

(DE)

Die Kühlerleistung des Fahrzeuges muß bei Nachrüstung einer Anhängerkupplung möglicherweise erhöht werden! Bitte unbedingt Herstellerangaben beachten!!

**ATTENTION!**

(FR)

Il peut s'avérer nécessaire d'augmenter la puissance du radiateur du véhicule lorsque celui est équipé ultérieurement d'un attelage remorque! Respecter impérativement les instructions du constructeur!!

**ATTENTIE!**

(NL)

Het koelvermogen van het voertuig moet mogelijk worden verhoogd als achteraf een aanhangerkoppeling wordt aangebracht! Absoluut de fabrieksopgaven in acht nemen a.u.b.!!

**ATTENTION!**

(GB)

The vehicle's cooling capacity may have to be increased when retrofitting a trailer coupling! You must observe the manufacturer's instructions!!

**¡ATENCIÓN!**

(ES)

¡Es posible que haya que aumentar la capacidad del radiador en caso de reequipar un acoplamiento de remolque! ¡Rogamos tener en cuenta las instrucciones de fabricante sin falta!

**ATTENZIONE!**

(IT)

La capacità di raffreddamento del veicolo, quando si applica un gancio di traino, si deve possibilmente aumentare! Si prega di osservare tassativamente le indicazioni del produttore!!

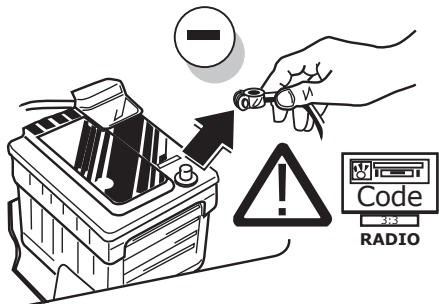

(DE)

Um Störungen und Schäden am Bordnetz zu vermeiden, muss die Massepolklemme unbedingt vor Beginn aller Arbeiten von der Fahrzeugbatterie getrennt werden! Insbesondere bei Arbeiten und Anschlüssen am CAN-Datenbus kann bei nicht abgeklemmter Batterie sowohl das Anhängermodul als auch das fahrzeugseitige Bordnetzsteuergerät beschädigt werden! Bitte Herstellervorschriften beim Ab- und Anklemmen der Fahrzeugbatterie beachten!

(FR)

Afin d'éviter tout dys-fonctionnement ou endom-magement du circuit de bord, il est indispensable de débrancher la pince de masse de la batterie du véhicule avant le début de toute opération! En particulier s'il s'agit de travaux et de branchements effectués sur le bus de données CAN, si la batterie n'est pas débranchée, le module remorque aussi bien que le dispositif de commande de circuit de bord du véhicule risquent d'être endommagés! Veuillez respecter les directives du fabricant lors du branchement et du débranchement de la batterie du véhicule!

(NL)

Om storingen en schade aan de elektrische bedrading te vermijden moet de massapoolklem absoluut vóór aanvang van alle werkzaamheden worden losgekoppeld van de voertuigaccu! Vooral bij werkzaamheden aan en aansluitingen op de CAN-databus kan zowel de aanhangermodule als de voertuigzijdige reguleenheid voor de elektrische installatie beschadigd worden, als de accu niet ontkoppeld is! Fabrieksvoorschriften bij het vast- en loskoppelen van de voertuigaccu in acht nemen a.u.b.!

(GB)

In order to avoid mal-functions and damage to the vehicle's electrical system the earth terminal must be disconnected from the vehicle's battery before starting work! Both the trailer module and the vehicle's control unit for the electrical system can be damaged during work on the CAN data bus connections if the battery is not disconnected! Please pay attention to the manufacturer's instructions when disconnecting and reconnecting the vehicle's battery!

(ES)

¡Para evitar fallos y defectos en el sistema eléctrico de a bordo es imprescindible separar al terminal de puesta a tierra de la batería del vehículo antes de realizar cualquier trabajo! ¡Particularmente al realizar trabajos y conexiones al bus de datos CAN puede estropearse tanto el módulo para remolques como el regulador del sistema eléctrico de a bordo del vehículo si no se ha desconectado la batería! ¡Rogamos observar las instrucciones del fabricante al conectar y desconectar la batería del vehículo!

(IT)

Per evitare disturbi e danni alla rete di distribuzione elettrica, l'espansione polare a massa deve essere assolutamente scollegata dalla batteria del veicolo prima dell'inizio dei lavori! In particolare durante i lavori e gli allacciamenti al bus di dati CAN, se la batteria non è scollegata si possono danneggiare sia la centralina rimorchio, sia la centralina della rete di distribuzione elettrica del veicolo! Attenersi alle indicazioni del costruttore per scollegare e ricollegare la batteria del veicolo!

## Saloon/ Coupe/ Cabriolet

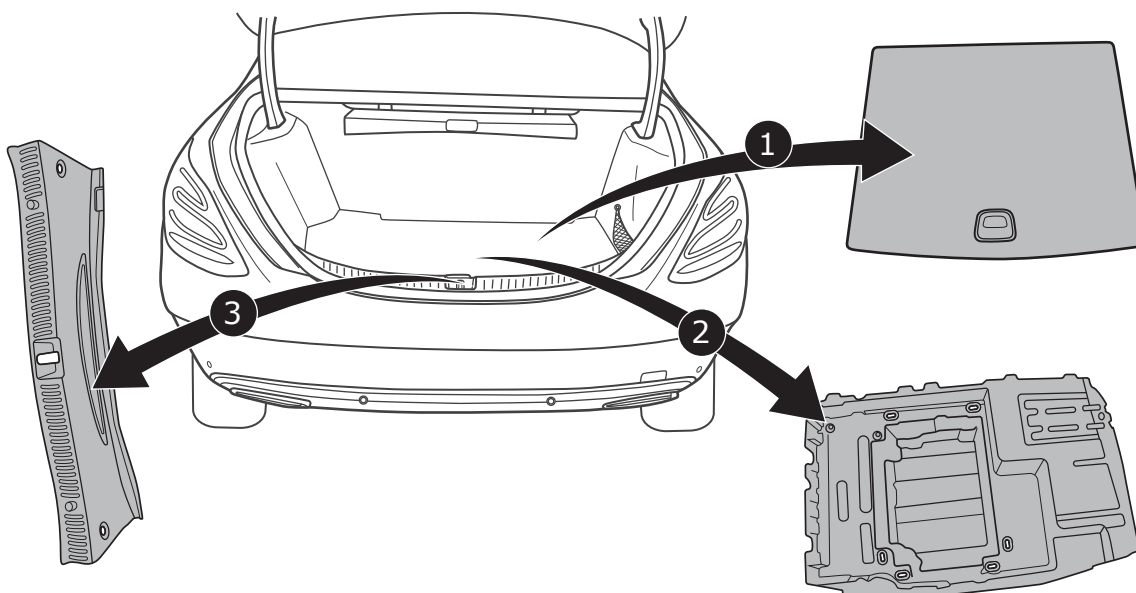

Saloon/ Coupe/ Cabriolet

5

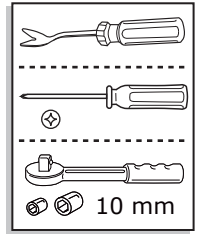
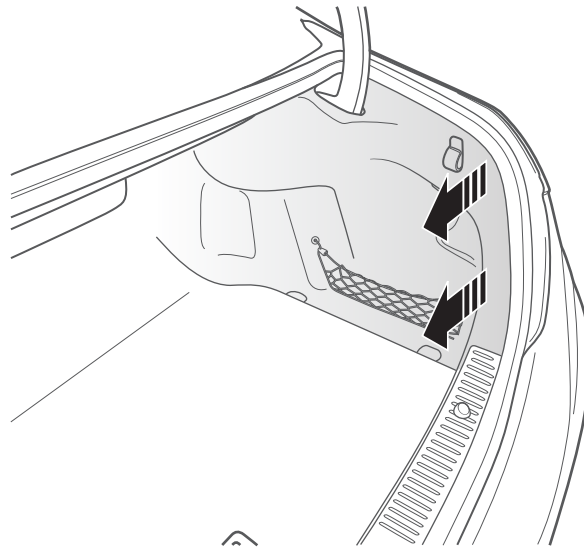
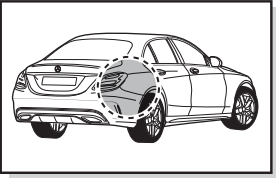

Estate

6

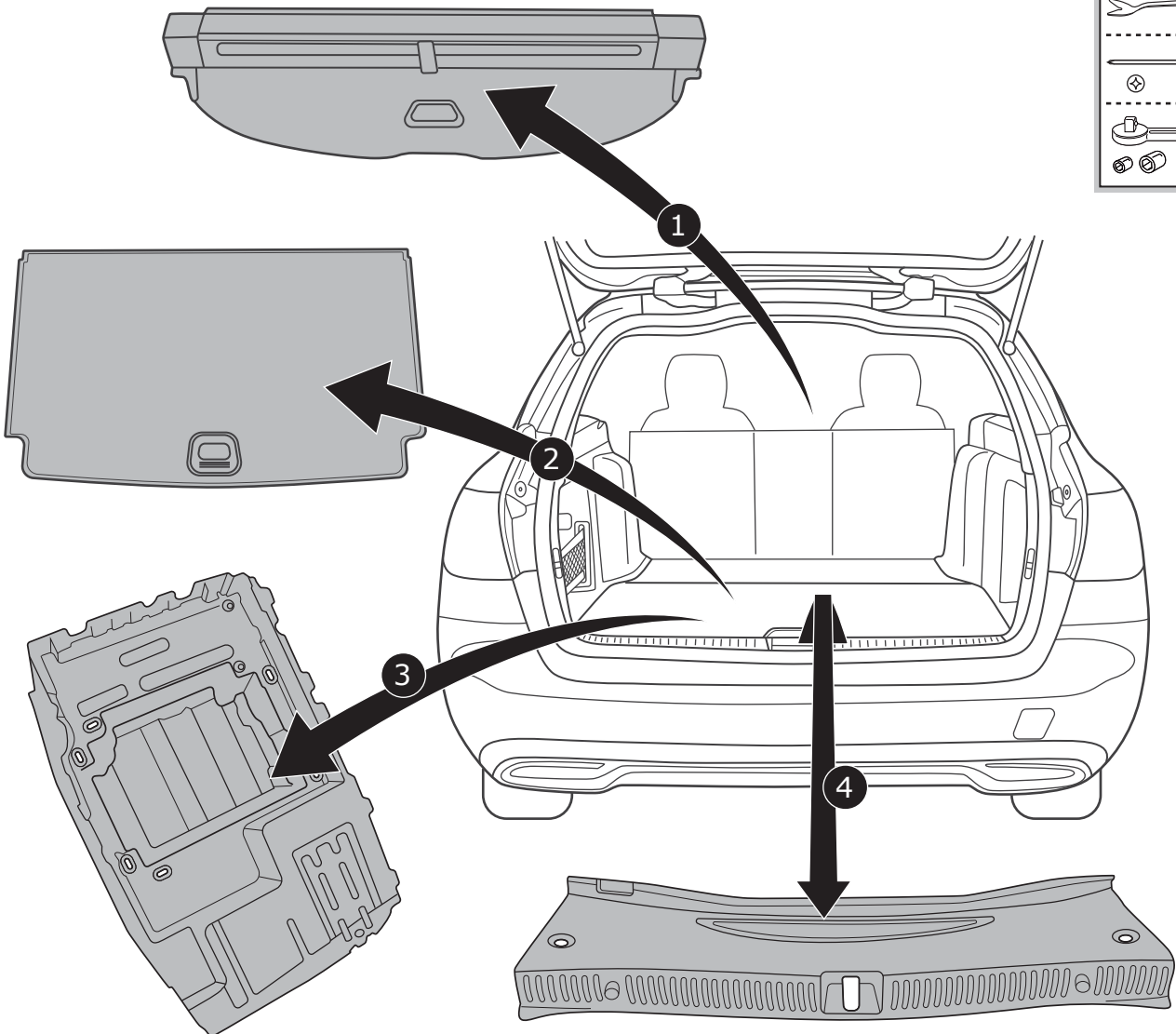
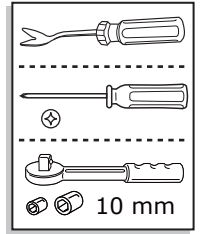

All models

7

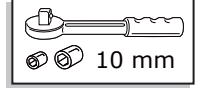
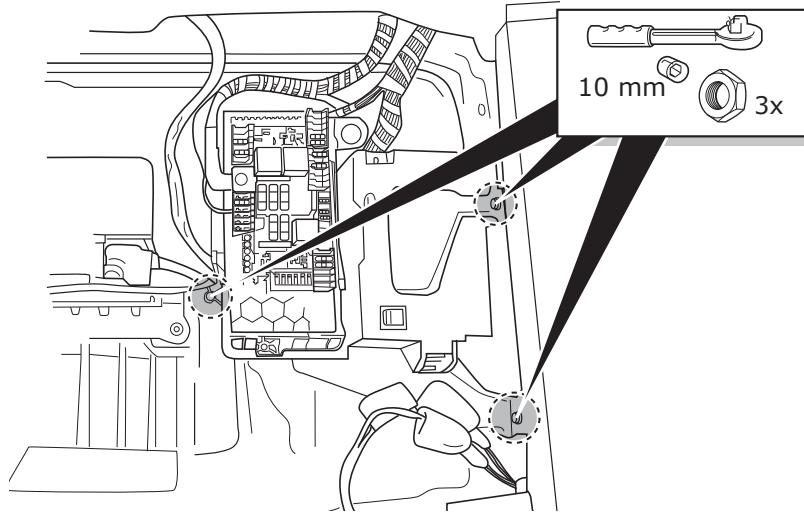
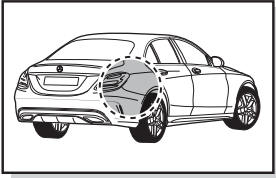

Estate

8

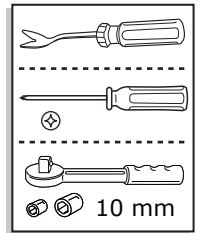
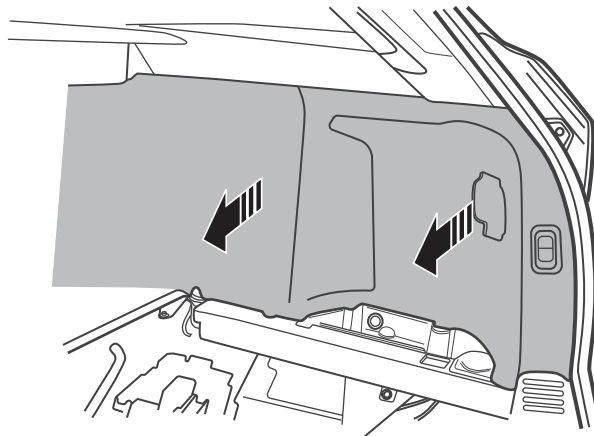
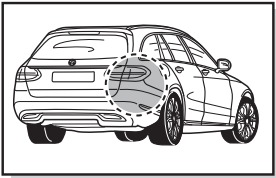

All models

9

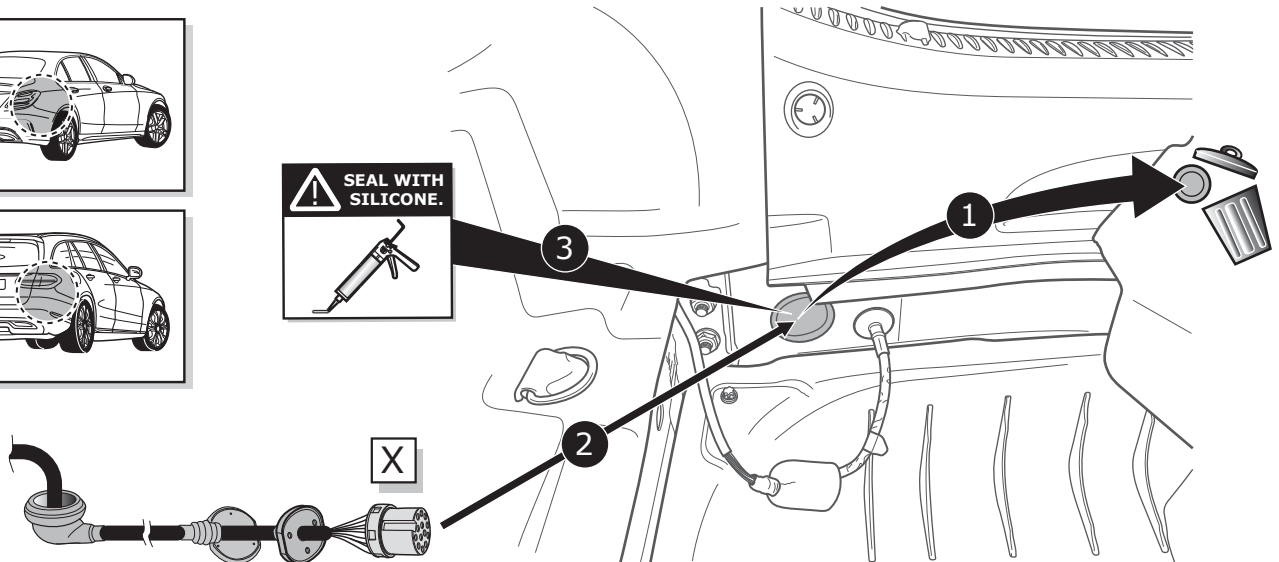
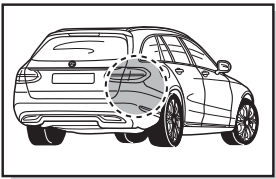
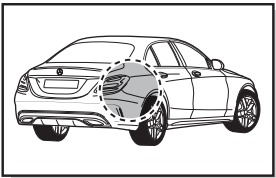

10

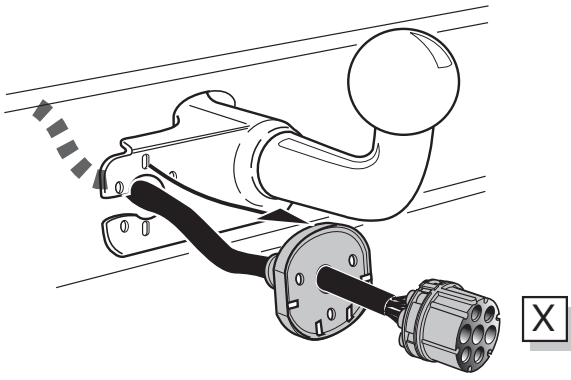

11

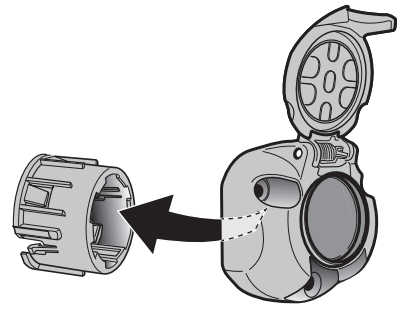

12

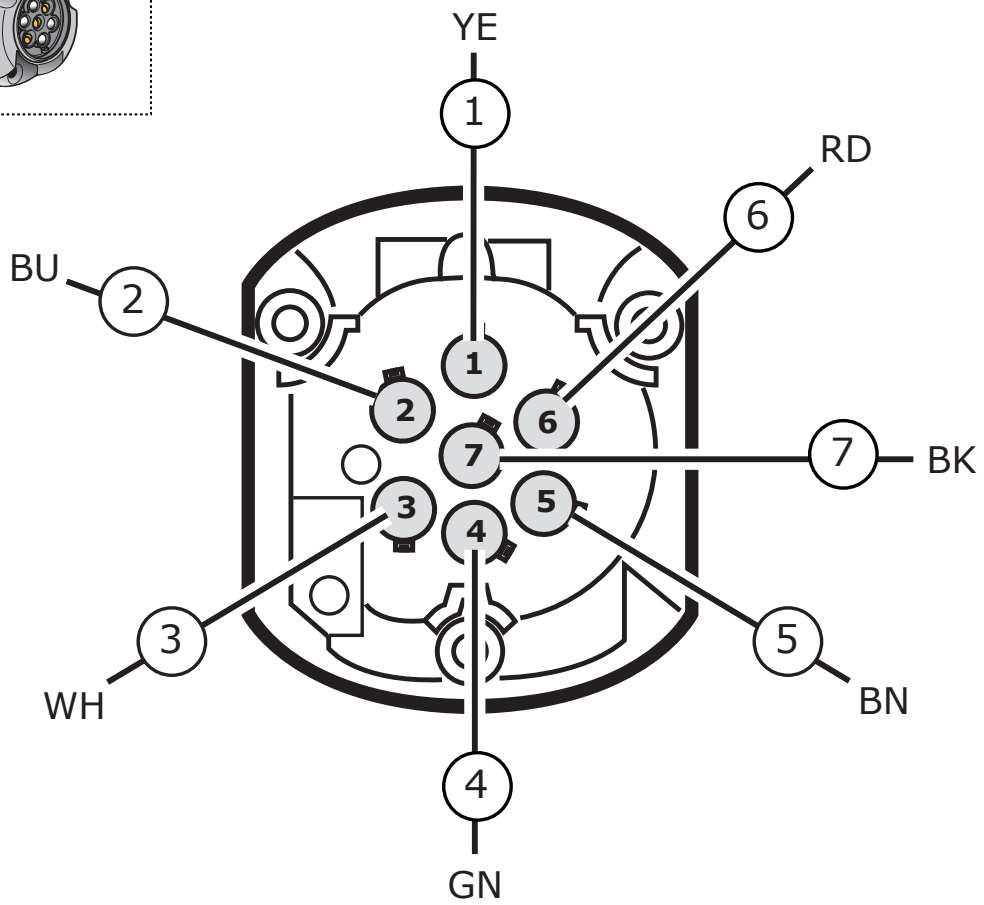
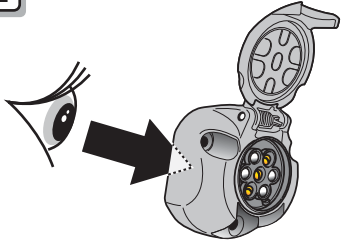

SOCKET CONNECTION

DIN/ISO 1724							
Pmax	21W	21W		21W	52W	3x21W	52W
Colour	Yellow	Blue	White	Green	Brown	Red	Black



13

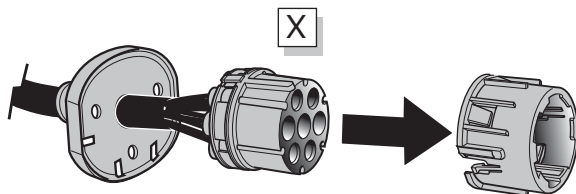

14

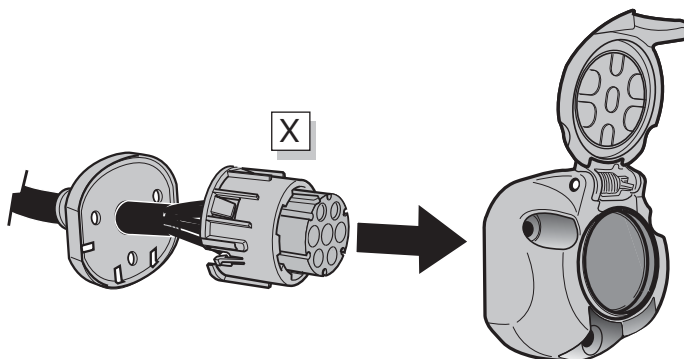

15

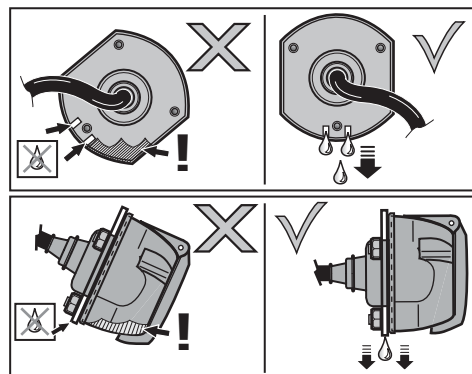
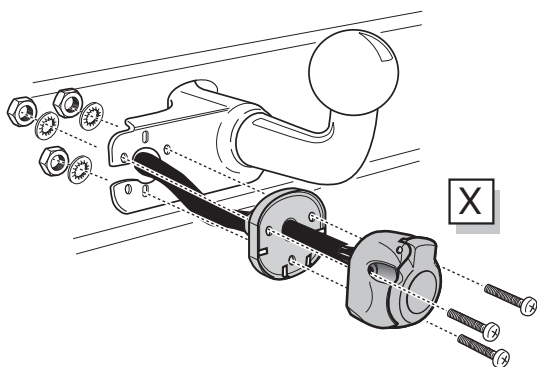

16

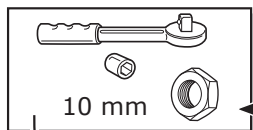
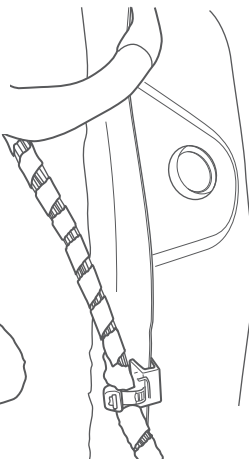
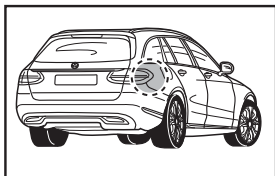
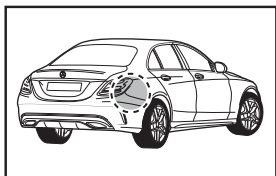

10 mm

1

2

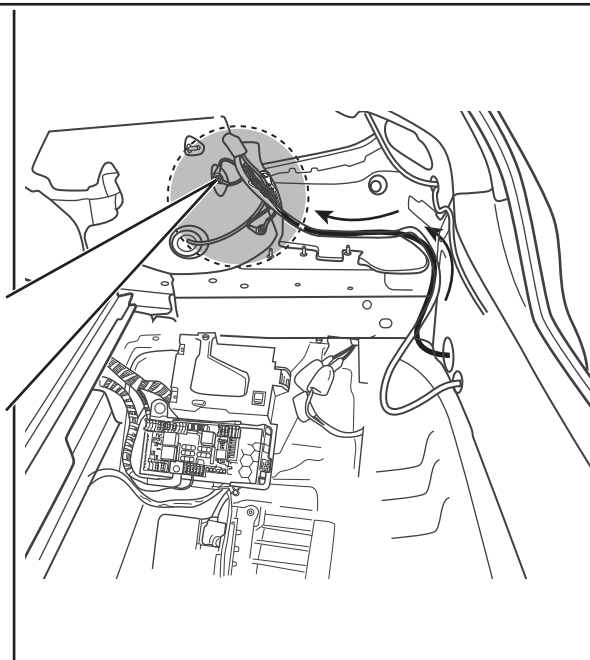

17

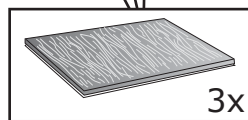
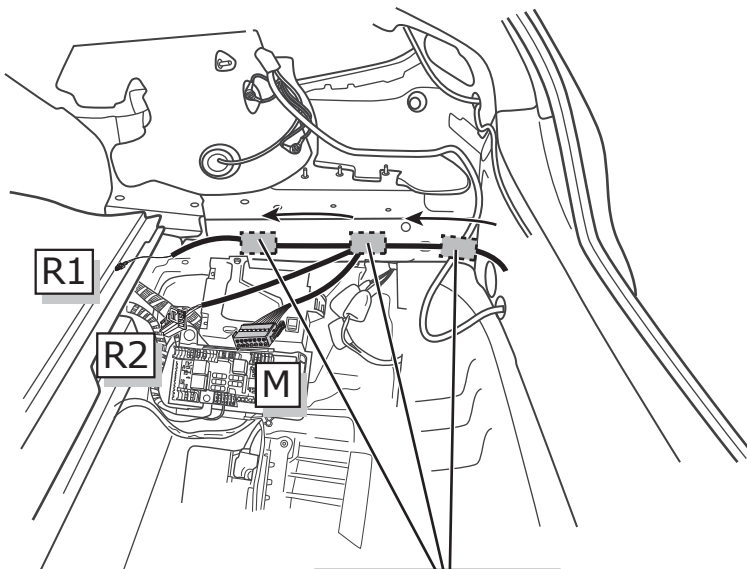
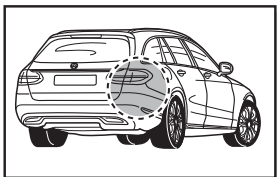
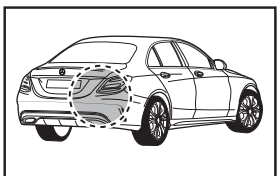

18

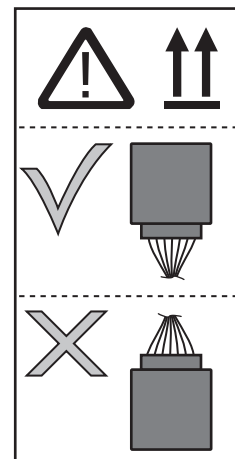
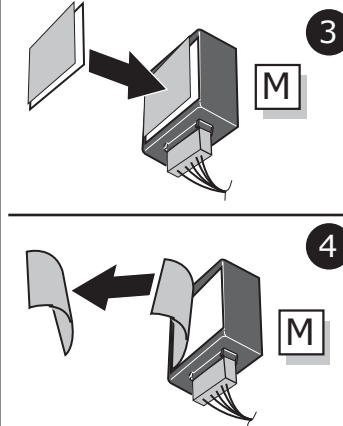
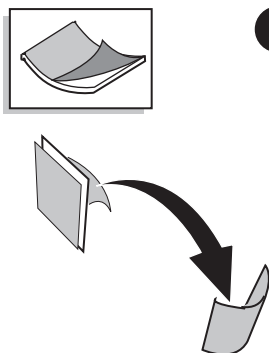
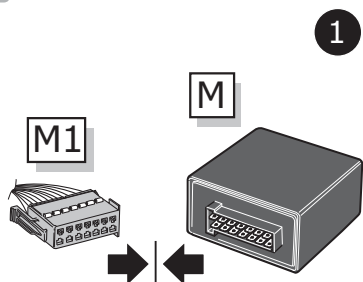

19

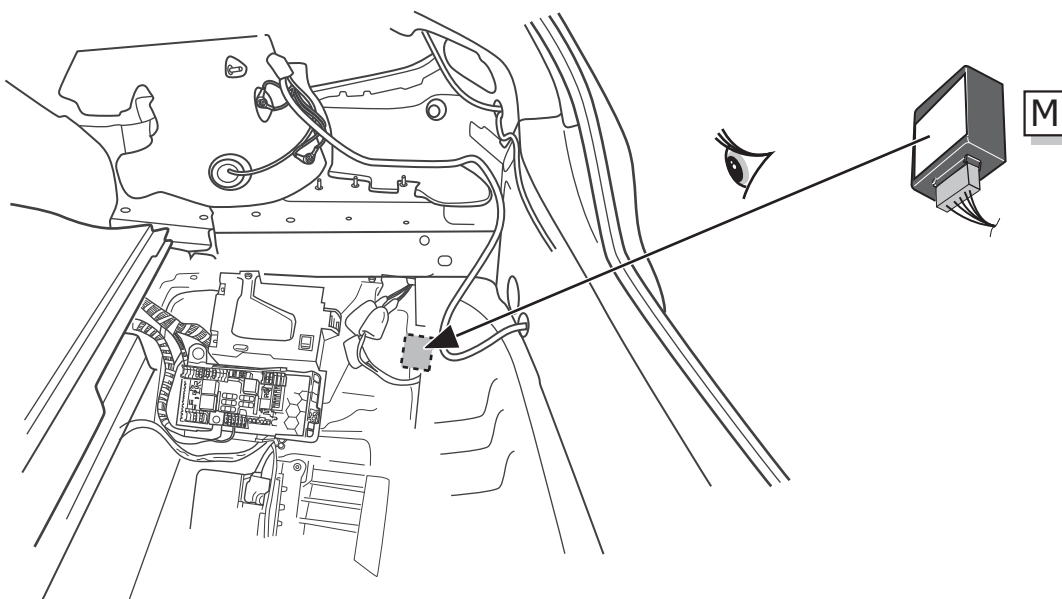
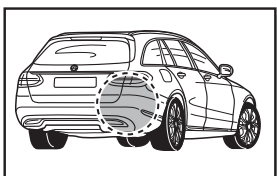
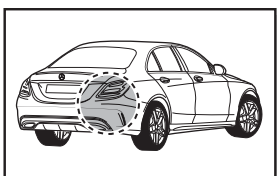

Important!  
Please note informations in picture 3!

20

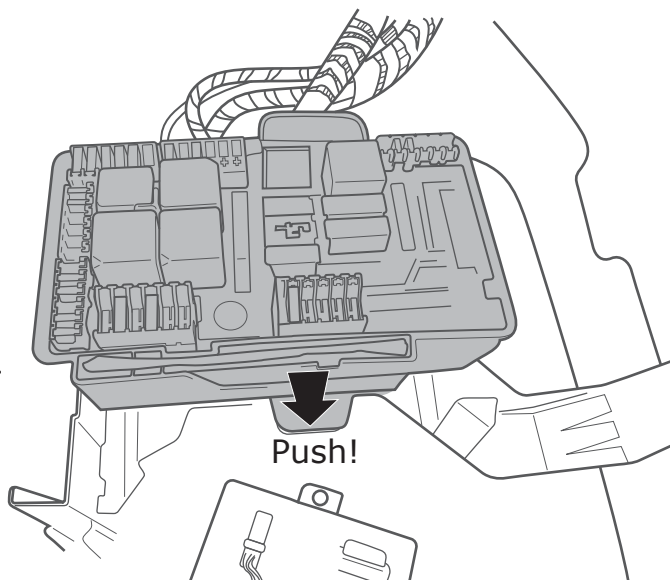
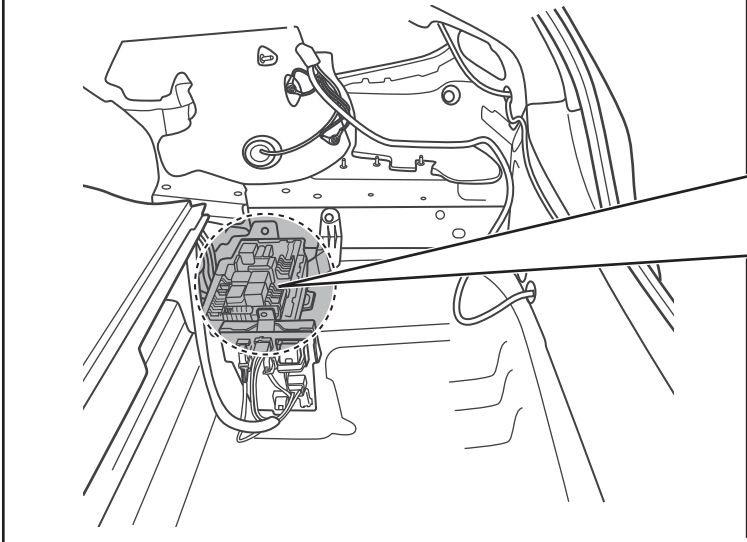
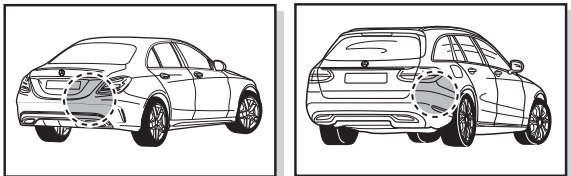

21

1

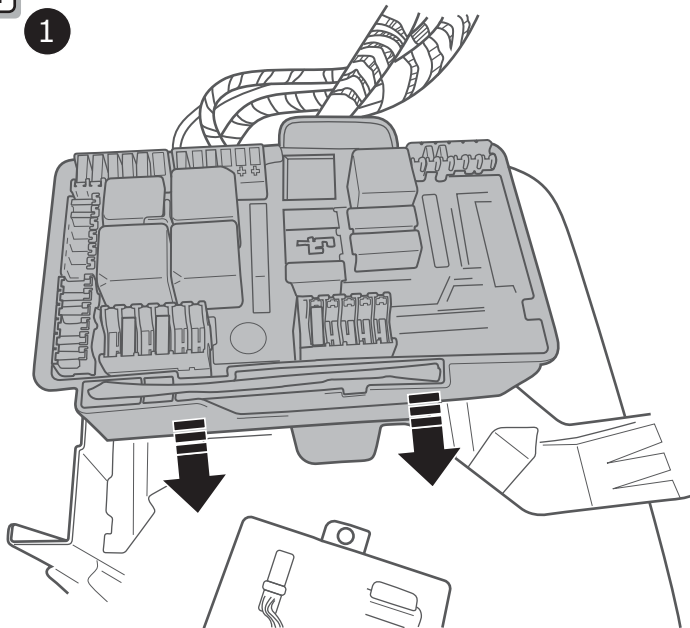

2

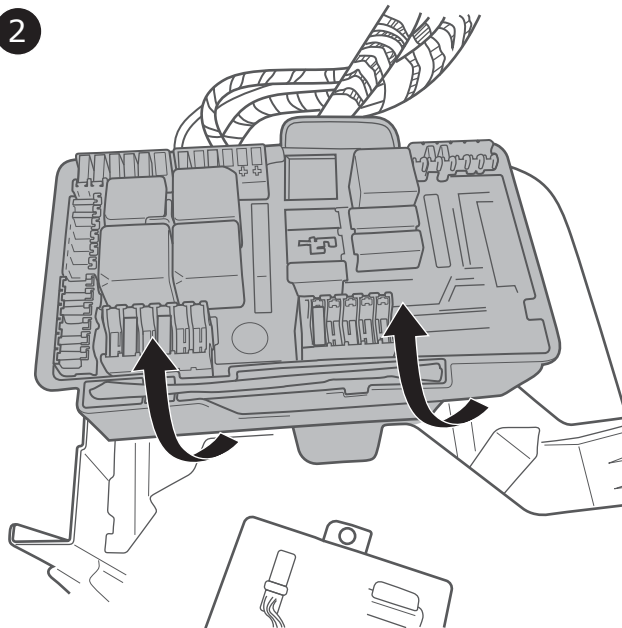

3

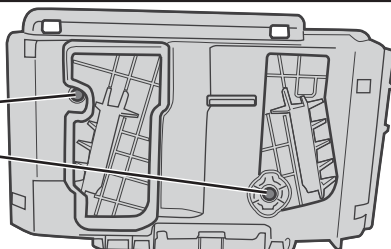
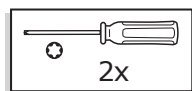

22

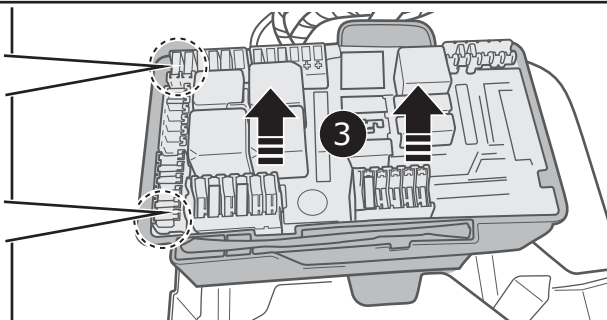
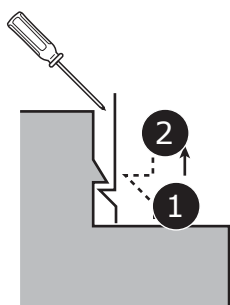

23

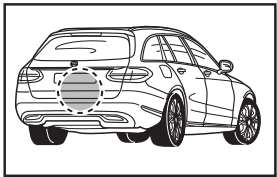
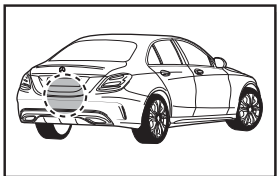

B+/30

Option 1

PE

Option 2

BU

Option 3

GN

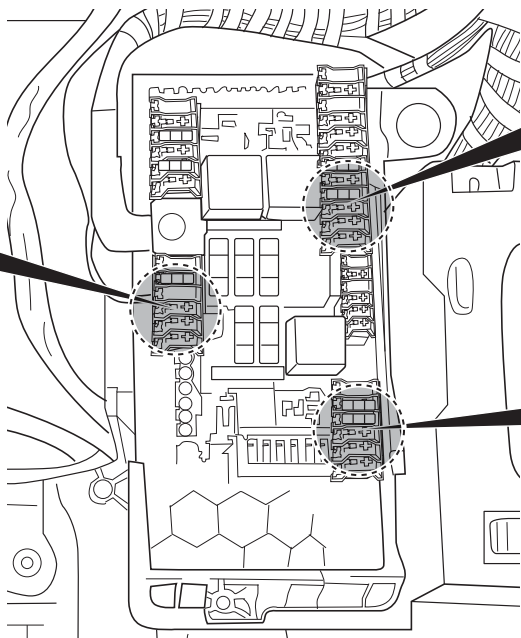

24

Option 1

Option 2

Option 3

Locate 2 unoccupied fuse plug-in positions (B+/30)!

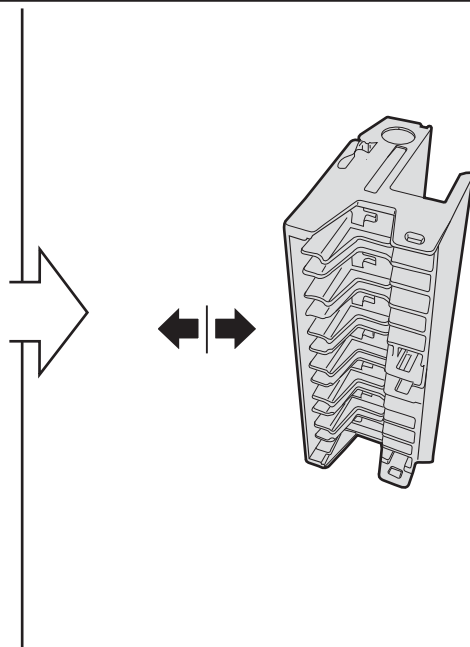
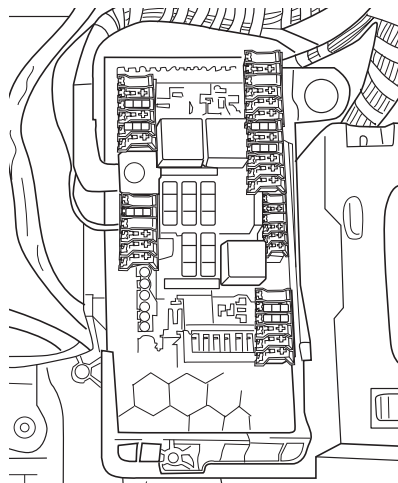

25

Option 1

Option 2

Option 3

20 Amp.



B+/30

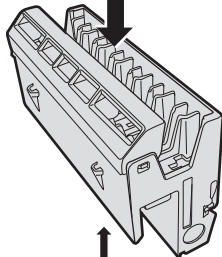

R1

RD/BU



20 Amp. minifuse

RD/BU

26



	<b>POS.</b>
RD/ BU 20 Amp.	.....

27

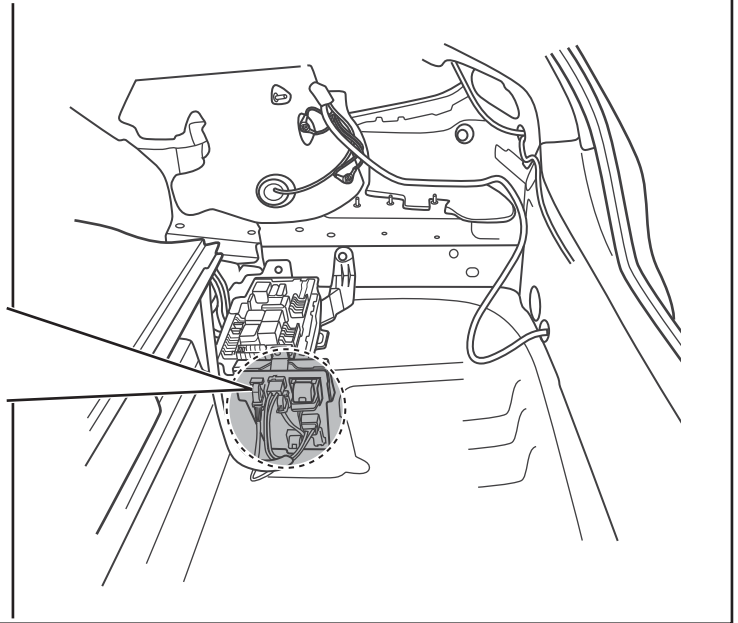
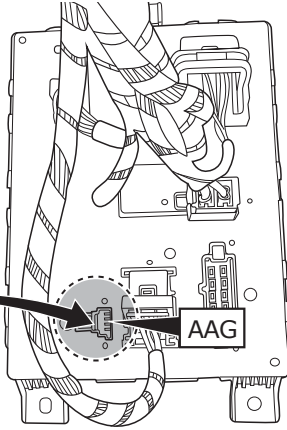
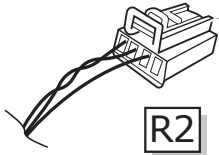
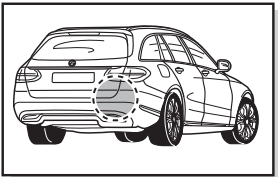
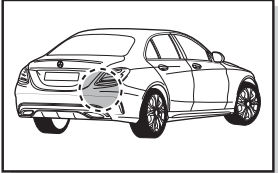

28

**Optional**



**MAX = 21W**

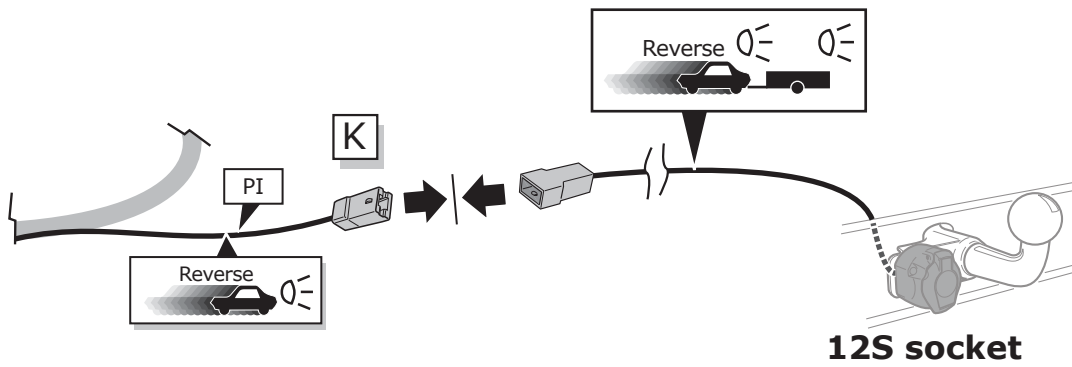

29

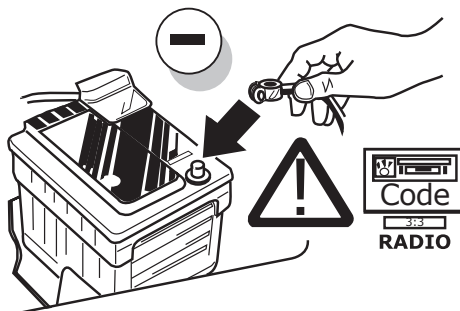

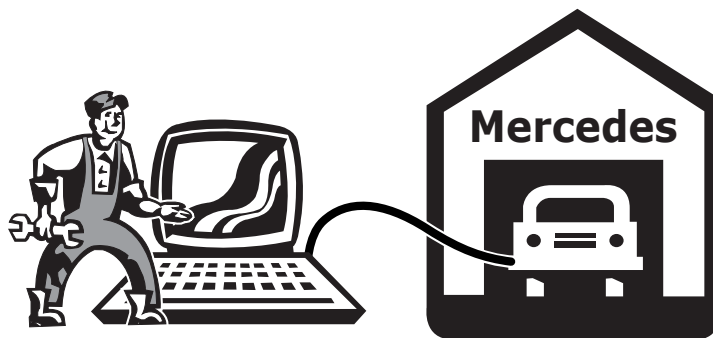

(DE)

(GB)

(FR)

**Die Aktivierung der Anhängerfunktionen muss wie folgt durchgeführt werden:**

1. Computer mit Auto verbinden
  2. Programm starten
  3. Klicke auf „Sonderfunktionen“
  4. Klicke auf "Eingabe bei Nachrüstungen oder Umbauten"
  5. Gebe Benutzername und Passwort ein
  6. Schreibe 550 beim oberen (+) Feld ein
  7. Akzeptiere und beende das Programm.
  8. Starte Programm erneut
  9. Klicke auf „Steuergeräte Ansicht“
  10. Verbaute Steuergeräte wie folgt programmieren:
    - a. Klicke z.B. auf „EZS“ (Elektronisches Zündschloss)
    - b. Klicke auf „Anpassung“
    - c. Auf der linken Seite: Klicke auf Aktualisierung SCN-Codierung
    - d. Gehe online und warte ein paar Sekunden
  11. Vorgang mit allen unten aufgeführten Steuergeräten durchführen:
    - „EZS“ (Elektronisches Zündschloss)
    - „SAM-hinten“ (Signalerfass- und Ansteuermodul hinten.)
    - „SAM-vorn“ (Signalerfass- und Ansteuermodul vorn)
    - „Kombiinstrument“
    - „Headunit/Audio 20“
    - „Motor“
- Wenn verbaut:
- „Parksystem“
  - „360°-Kamera“
  - „Niveau-Regulierung“
  - „KEYLESS-GO“

► Ende der Codierung

**The activation of the trailer functions has to be carried as follows:**

1. Connect computer to car
  2. Start program
  3. Click "Special functions"
  4. Click "Input for retrofits or conversions"
  5. Enter you user name and password
  6. Write 550 in the upper (+) field
  7. Accept and close the program.
  8. Start the program again
  9. Click "Controllers View"
  10. code installed control units as follows:
    - a. Click e.g. "EZS" (Ignition)
    - b. Click "Adjust"
    - c. On the left side: click updating SCN encoding
    - d. Go online a wait a few seconds
  11. Perform the operation with all the control units listed below:
    - "EZS" (Ignition)
    - "SAM-rear" (Signal detection- and control modul rear).
    - "SAM-front" (Signal detection- and control modul front).
    - "combined instrument"
    - "headunit/Audio 20"
    - "Engine"
- if fitted:
- "Parksystem"
  - "360° camera"
  - "Level Control"
  - "KEYLESS-GO"

► Coding finished

**L'activation des fonctions de la remorque doit être effectuée comme suit:**

1. Relier l'ordinateur à la voiture
  2. Démarrer le programme
  3. Cliquez sur «Fonctions spéciales»
  4. Cliquez sur «Saisie pour rééquipement ou transformation»
  5. Saisissez le nom d'utilisateur et le mot de passe
  6. Inscrivez 550 dans la zone(+) en haut
  7. Acceptez et quittez le programme
  8. Redémarrez le programme
  9. Cliquez sur «Vue appareils de commande»
  10. Programmez des appareils de commande montés comme suit:
    - a. Cliquez p. ex. sur «EZS» (Allumage)
    - b. Cliquez sur «Adaptation»
    - c. Sur le côté gauche: Cliquez sur actualisation SCN Codage
    - d. Rendez-vous en ligne et attendez quelques secondes
  11. Effectuer la procédure avec toutes les unités de commande dans la liste ci-dessous:
    - «EZS» (Allumage)
    - «SAM-arrière»(Module de Commande en arrière)
    - «SAM-devant»(Module de Commande devant)
    - «instrument combiné»
    - «headunit/Audio 20»
    - «moteur»
- si installé:
- «Système de stationnement»
  - «Caméra panoramique»
  - «Contrôle de niveau»
  - «KEYLESS-GO»

► Fin de codage



IT

**L'attivazione di rimocchio funzioni si deve eseguire come segue:**

1. Collegare il computer con l'auto
  2. Avviare il programma
  3. Cliccare su „Funzioni speciali“
  4. Cliccare su "Immissione in caso di optional supplementari o modifiche"
  5. Digitare il nome utente e la password
  6. Digitare 550 nel campo superiore (+)
  7. Accettare e chiudere il programma.
  8. Riavviare il programma
  9. Cliccare su „Vista Comando centralina“
10. codite unità di controllo installato come segue
- a. Cliccare p.es. „EZS“ (Blocco di accensione)
  - b. Cliccare su „Adattamento“
  - c. Sul lato sinistro:  
cliccare su attualizzazione SCN Codifica
  - d. Collegarsi online e aspettare alcuni secondi
11. Eseguire la procedura con tutte le centraline di seguito elencati:
- „EZS“ (Blocco di accensione)
  - „SAM dietro“ (Modulo di controllo dietro)
  - „SAM avanti“ (Modulo di controllo avanti)
  - „strumenta combinato“
  - „headunit/Audio 20“
  - „motore“
- se installato:
- „Sistema di parcheggio“
  - „Telecamera a 360°“
  - „Controllo di livello“
  - „KEYLESS-GO“
- Fine della codifica

ES

**La activación del funciones de remolque deberá llevarse a cabo de la siguiente manera:**

1. Conectar el ordenador con el coche
  2. Iniciar el programa
  3. Hacer clic en "Funciones especiales"
  4. Hacer clic en "Entradas en caso de reequipamientos o modificaciones"
  5. Introducir el nombre de usuario y la contraseña
  6. Introducir 550 en la casilla superior (+)
  7. Aceptar la entrada y finalizar el programa.
  8. Volver a iniciar el programa
  9. Hacer clic en "Ver reguladores"
10. código instalado unidades de control de la siguiente
- a. Hacer clic por ejemplo en "EZS" (Ignición)
  - b. Hacer clic en "Adaptación"
  - c. En el lado izquierdo: Hacer clic en actualización SCN Codificación
  - d. Conectarse en línea y esperar un par de segundos
11. Realice el procedimiento con todas las unidades de control que se indican a continuación:
- "EZS" (Ignición)
  - "SAM-atrás" (Módulo de control atrás)
  - "SAM-delante" (Módulo de control delante)
  - "instrumento combinado"
  - "headunit/Audio 20"
  - "motor"
- si está instalado:
- "Sistema de estacionamiento"
  - "Cámara de 360°"
  - "Control de nivel"
  - "KEYLESS-GO"
- Fin de la codificación

NL

**De activering van de trailerfuncties moet als volgt worden uitgevoerd:**

1. Computer met auto verbinden
  2. Programma starten
  3. Klik op „Speciale functies“
  4. Klik op "Invoer bij achteraf toegevoegde onderdelen of modificaties"
  5. Voer gebruikersnaam en wachtwoord in
  6. Schrijf 550 in het bovenste (+) veld
  7. Accepteer en beëindig het programma.
  8. Start programma opnieuw
  9. Klik op „Bekijk besturingsapparaten“
10. code geïnstalleerd besturingsapparaten als volgt
- a. Klik bijvoorbeeld op „EZS“ (Ignition)
  - b. Klik op „Aanpassing“
  - c. Aan de linkerkant:  
klik op update SCN-codering
  - d. Ga online en wacht een paar seconden
11. Voer de proces met alle hieronder genoemde besturingsapparaten:
- „EZS“ (Ignition)
  - „SAM achter“ (Signal detection- and control modul achter)
  - „SAM vooraan“ (Signal detection- and control modul vooraan)
  - „kombi-instrument“
  - „headunit/Audio 20“
  - „motor“
- indien geïnstalleerd:
- „Parking system“
  - „360°-camera“
  - "Level Control"
  - "KEYLESS-GO"

► Uiteinde van het coderende

30

**Optional**

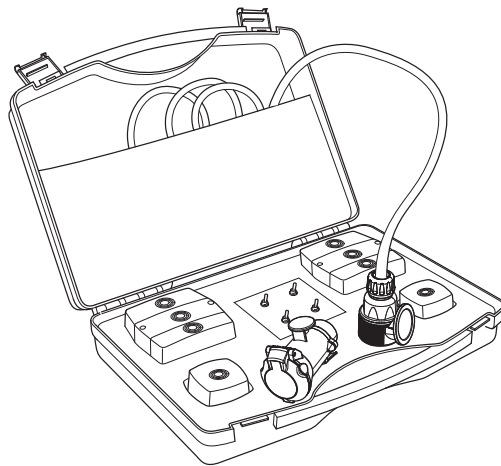

Trailer Simulator  
for 7p and 13p  
Sockets  
**765069**

31

**Functional test**

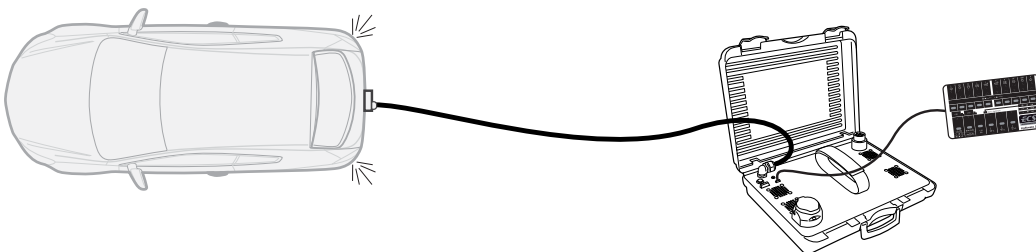
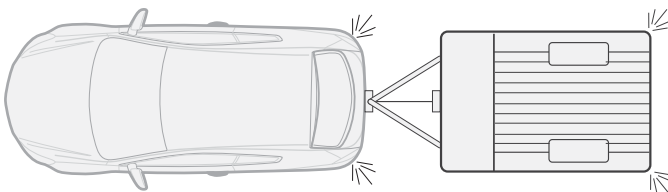
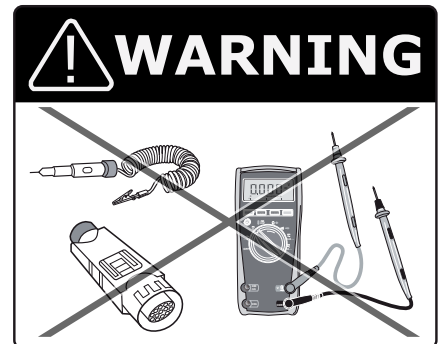
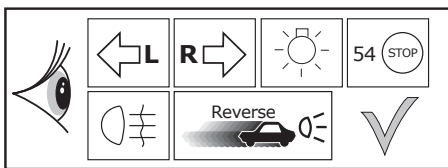

32

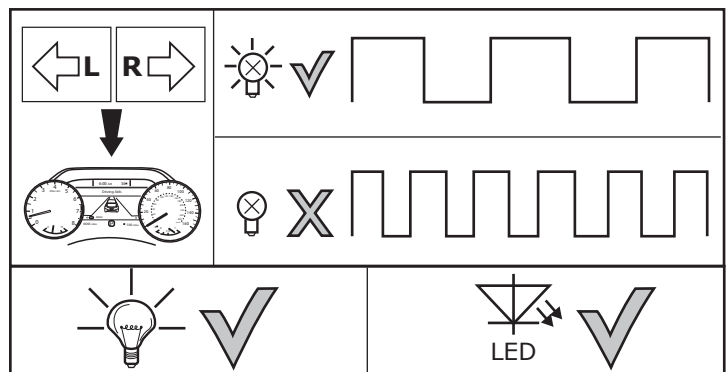
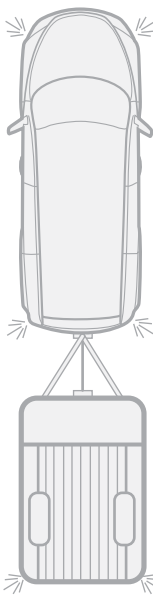

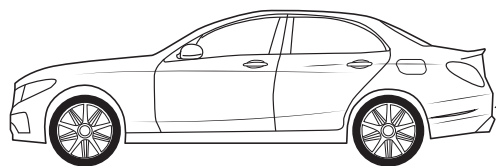

33

**Optional****Adapter socket  
768019**

7-pin

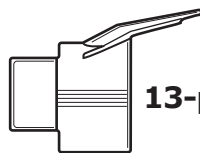

13-pin

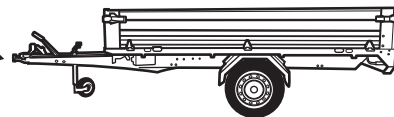

34

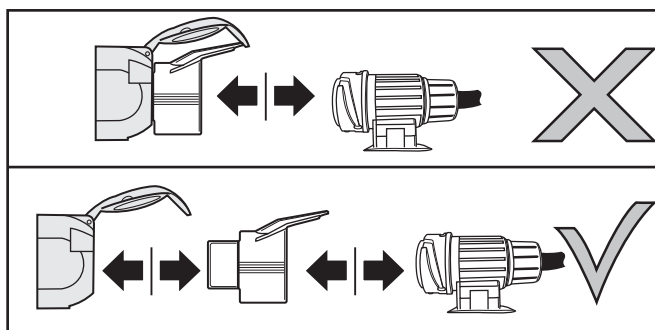
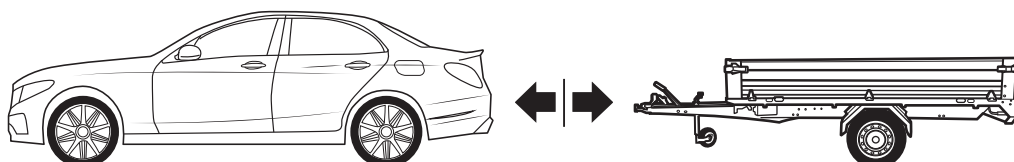

35

- |                                    |                                      |
|------------------------------------|--------------------------------------|
| (DE) Einzelteile wieder einbauen   | (CZ) Znovu zasuňte obložení          |
| (FR) Remonter les pièces démontées | (DK) Påsæt beklædningen              |
| (NL) Terug plaatsen onderdelen     | (FI) Asenna verhoilut takaisin       |
| (GB) Reinstall linings             | (GR) Τοποθετήστε ξανά τις επενδύσεις |
| (ES) Reinstalar componentes        | (NO) Sett tilbake deler              |
| (IT) Rimetti a posto componenti    | (PL) Założyć wykładzinę              |
| (SE) Sätt tillbaka delar           |                                      |

36

- |                               |
|-------------------------------|
| (DE) Einbauanleitung          |
| (FR) Instructions de montage  |
| (NL) Montage-handleiding      |
| (GB) Fitting instructions     |
| (ES) Instrucciones de montaje |
| (IT) Istruzioni di montaggio  |
| (SE) Monteringsanvisningar    |
| (CZ) Montážní pokyny          |
| (DK) Monteringsvejledninger   |
| (FI) Ohjeet asentamiseen      |
| (GR) Οδηγίες συναρμολόγησης   |
| (NO) Monteringsanviser        |
| (PL) Instrukcje montażu       |

